

ALBEAMOBILI
ITALIA

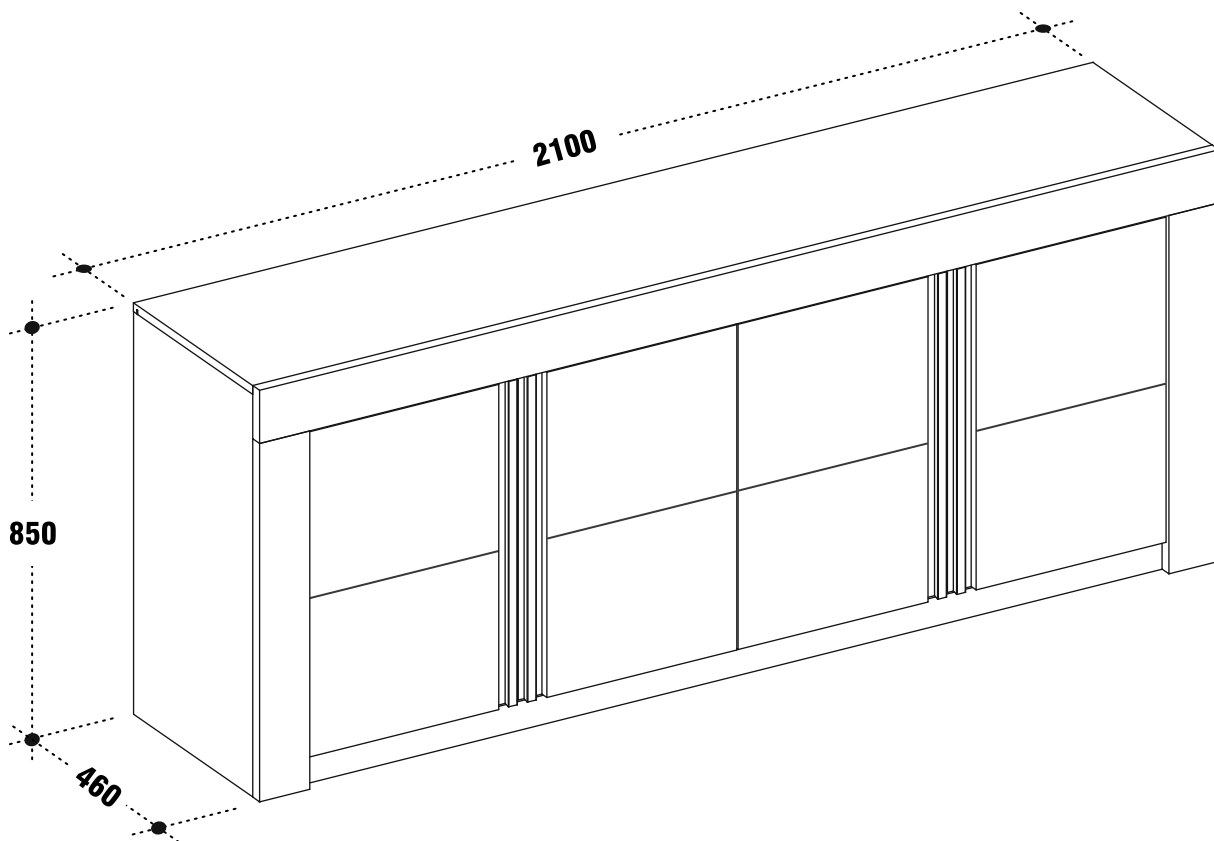

notice de montage
enfilade 210 **CAPRI**
4 portes

**ITALIANO****CONSIGLI DI MONTAGGIO:**

- Studiare bene le istruzioni di montaggio.
- Prendere conoscenza dei pezzi che costituiscono il mobile.
- Raggruppare e controllare la ferramenta.
- Munirsi degli utensili necessari.
- Preparare una zona di montaggio
- Procedere al montaggio

AVVERTENZA

NON FORZARE MAI GLI ASSEMBLAGGI. RISTRINGERE LE VITI DOPO UN PERIODO D'USO. CONSERVARE QUESTE ISTRUZIONI DI MONTAGGIO. SE UN PEZZO VENISSE A MANCARE SAREBBE IL MIGLIORE MEZZO DI COMUNICAZIONE CON IL RIVENDITORE.

CONSIGLI PER LA MANUTENZIONE:

E' sufficiente spolverare regolarmente con un panno asciutto, morbido e pulito, preferibilmente nella direzione del disegno. Le macchie possono essere eliminate con un panno leggermente umido; in ogni caso asciugare subito. Non usare in nessun caso cera, olio, spray per mobili e prodotti chimici.

ESPAÑOL**CONSEJOS PARA EL MONTAJE:**

- Studiare bene le istruzioni di montaggio.
- Prendere conoscenza dei pezzi che costituiscono il mobile.
- Raggruppare e controllare la ferramenta.
- Munirsi degli utensili necessari.
- Preparare una zona di montaggio
- Procedere al montaggio

ADVERTENCIA

NUNCA FUERCE LOS ENSAMBLAJES. APRIETE LOS TORNILLOS DESPUÉS DE UN PERÍODO DE USO. MANTENGA ESTAS INSTRUCCIONES DE MONTAJE. SI FALTA UNA PIEZA SERÍA EL MEJOR MEDIO DE COMUNICACIÓN CON EL DISTRIBUIDOR.

CONSEJOS PARA EL MANTENIMIENTO:

Es suficiente espolvorear regularmente con un paño seco, suave y limpio, preferiblemente en la dirección del dibujo. Las manchas se pueden quitar con un paño ligeramente húmedo; en cualquier caso, secar de inmediato. Nunca use cera, aceite, spray para muebles y productos químicos.

FRANÇAIS**CONSEILS DE MONTAGE:**

- Bien etudier la notice de montage.
- Reperez les pieces constituant votre meuble, constituiscono il mobile.
- Regroupez et controlez la quincaillerie.
- Munissez-vous de l'outillageneccessaire.
- Aménagez-vous une zone de montage.
- Procédez au montage.

AVERTISSEMENT

NE JAMAIS FORCER LES ASSEMBLAGES. RESSERREZ LES VIS APRES QUELQUES TEMPS D'USAGE. GARDER VOTRE NOTICE DE MONTAGE, SI UNE PIECE VENAIT A MANQUER, ELLE SERAIT LE PLUS CLAIR MOYEN DE COMMUNIQUER AVEC VOTRE MAGASIN.

CONSEILS D'ENTRETIEN:

Enlevez régulièrement la poussière avec un chiffon propre, doux et sec, en suivant la structure du dessin. Les taches s'enlèvent avec un tissu légèrement humide, puis séchez la surface immédiatement. N'utilisez jamais de la cire, de l'huile, du vaporisant meuble ou des produits d'entretien contenant de produits chimiques.

ENGLISH**ASSEMBLY ADVICE:**

- Carefully read the assembly instruction.
- Identify the components of the furniture.
- Group and check the hardware.
- Use the required tools.
- Create an assembly zone.
- Make the assembly.

WARNING

NEVER FORCE THE CONNECTIONS. RE-TIGHTEN THE SCREWS AFTER FEW DAYS. PLEASE RETAIN THE AI LEAFLET FOR FUTURE REFERENCE. THE AI CONTAINS INFORMATION WHEN CLAIMING FOR MISSING PARTS.

CLEANING ADVICE:

Regularly dust with a clean soft dry cloth following the direction of the foil imprints. Stains should be removed using a damp cloth. The area should be dried off straight after cleaning. Do not use wax, oils, furniture spray or any cleansing agents containing chemicals.

DEUTSCH**MONTAGE ANLEITUNG:**

- Die montageanleitung sorgfältig durchlesen.
- Die einzelteile des mobilstücks ermitteln.
- Die beschläge zusammenlegen und prüfen.
- Das notwendige werkzeug zurechtlegen.
- Einen montagebereich freimachen.
- Das mobilstück zusammenbauen.

ACHTUNG

NIEMALS DIE VERBINDUNGEN ZU STARK ANZIEHEN. DIE SCHRAUBEN NACH EINIGER ZEIT DES GEBRAUCHS ERNEUT FESTZIEHEN. DIE MONTAGEANLEITUNG GUT AUFBEWAHREN: SOLLTE EIN TEIL FEHLEN, ISTSIE DAS BESTE VERSTÄNDIGUNGSMITTEL MIT IHREM GESCHAFT.

PFLEGEHINWEISE:

Es reicht aus, regelmäßig mit einem trockenen, weichen und sauberen Tuch zu stäuben, vorzugsweise in Zeichenrichtung. Flecken können mit einem leicht feuchten Tuch entfernt werden. In jedem Fall sofort trocknen. Verwenden Sie niemals Wachs, Öl, Möbelspray oder Chemikalien.

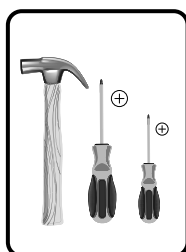
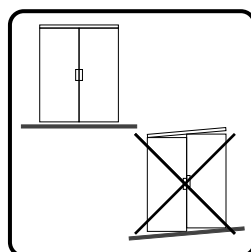
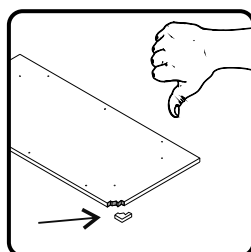
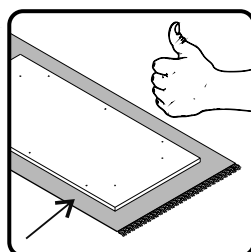

**ITALIANO**

Informazioni importanti.
Leggi attentamente.
Conserva queste informazioni per ulteriori consultazioni.

AVVERTENZA

Se il mobile si ribalta può causare lesioni da compressione serie o fatali. Per prevenire il rischio che il mobile si ribalti, quest'ultimo deve essere fissato permanentemente alla parete.

Gli accessori per il fissaggio alla parete non sono inclusi perché pareti di materiali diversi richiedono tipi diversi di accessori di fissaggio. Usa sistemi di fissaggio adatti alle pareti della tua casa. Per maggiori dettagli, rivolgiti a un rivenditore specializzato.

FRANÇAIS

Information importante
A lire attentivement.
Conserver ces informations pour un usage ultérieur.

AVERTISSEMENT

Risque de blessure grave en cas de chute du meuble. Pour éviter que le meuble ne bascule, il faut le fixer au mur de façon permanente.

Les fixations ne sont pas incluses car leur choix dépend du matériau du mur sur lequel est fixé le meuble. Utilisez des fixations adaptées au matériau du mur. Pour obtenir des conseils sur les fixations à utiliser, adressez-vous à un revendeur spécialisé.

ENGLISH

Important information
Read carefully.
Keep this information for further reference.

WARNING

Serious or fatal crushing injuries can occur from furniture tip-over. To prevent this furniture from tipping over it must be permanently fixed to the wall.

Fixing devices for the wall are not included since different wall materials require different types of fixing devices. Use fixing devices suitable for the walls in your home. For advice on suitable fixing systems, contact your local specialized dealer.

ESPAÑOL

Información importante
Leer detenidamente.
Guarda esta información para consultarla en el futuro.

ADVERTENCIA

Pueden producirse lesiones graves o fatales si vuelca un mueble. Para evitar que vuelque este mueble, debe fijarse permanentemente a la pared.

No se incluyen los dispositivos de fijación, dado que los diversos materiales de pared requieren diferentes tipos de herrajes de fijación. Usa herrajes adecuados para el material de las paredes de tu casa. Para saber cuáles son los herrajes adecuados, pide consejo en tu ferretería habitual.

DEUTSCH

Wichtige Information
Sorgfältig lesen
Diese Information aufbewahren

ACHTUNG

Wenn Möbelstücke umkippen, können ernste oder lebensgefährliche Verletzungen durch Einklemmen die Folge sein.
Um zu verhindern, dass das Möbelstück umkippt, muss es fest an der Wand verankert werden.

Beschläge für die Wandbefestigung sind nicht beige packt, da sie von der jeweiligen Wandbeschaffenheit abhängig sind. Befestigungsbeschläge benutzen, die für die heimischen Wände geeignet sind. Bei diesbezüglichen Fragen den örtlichen Fachhandel zu Rate ziehen.

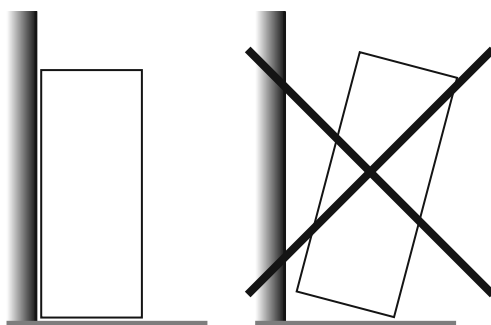

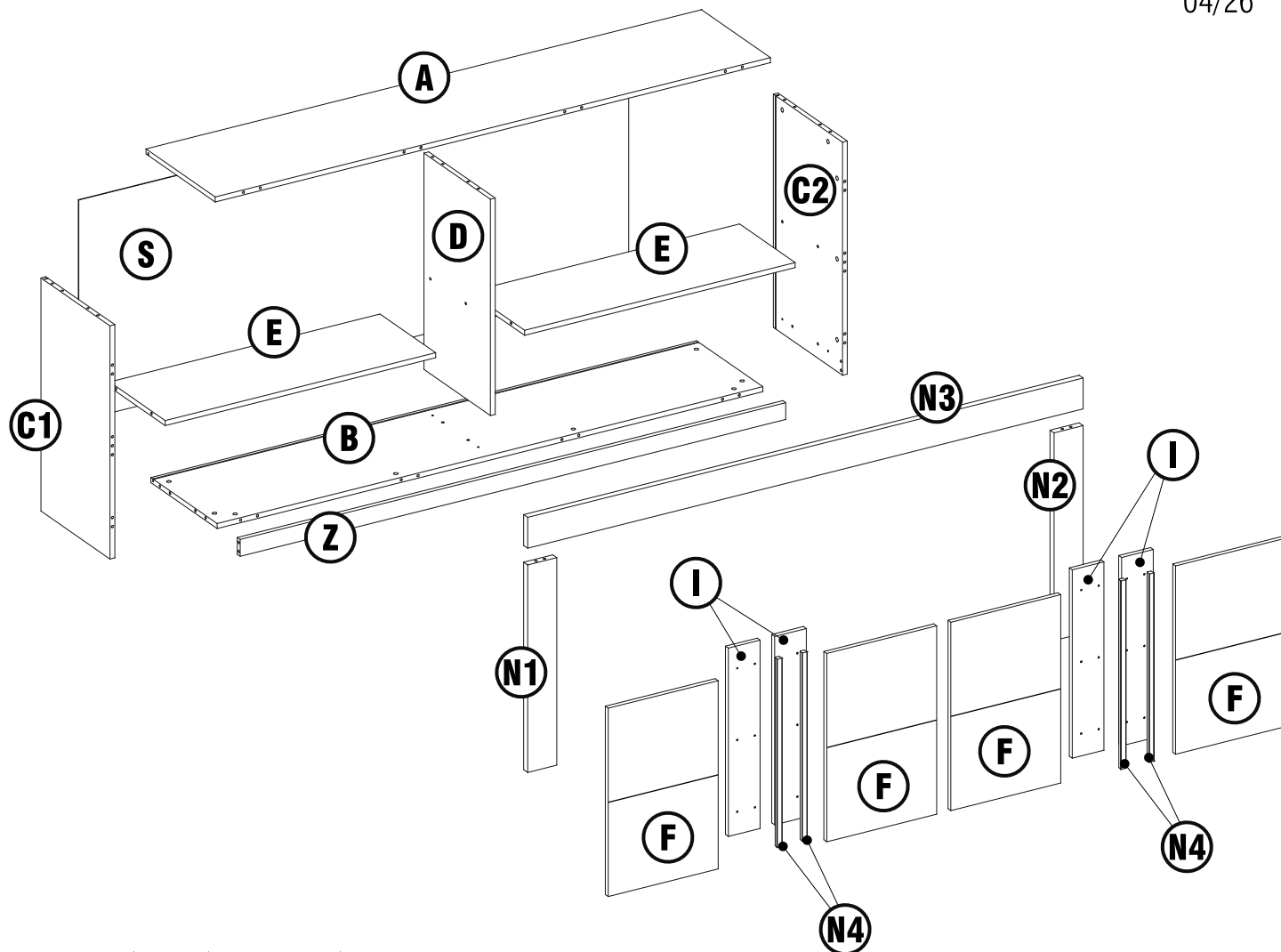

	N°	mm	package
(A)	x1	2102x435x18	1/1
(B)	x1	2065x417x18	1/1
(C1)	x1	832x435x18	1/3
(C2)	x1	832x435x18	1/3
(D)	x1	772x419x18	1/3
(E)	x2	1023x350x18	3/3
(F)	x4	672x416x18	1 / 2
(I)	x4	672x120x18	1 / 2
(N1)	x1	740.5x110x25	1/1
(N2)	x1	740.5x110x25	1/1
(N3)	x1	2102x110x25	1/1
(N4)	x1	20x17x672	1/1
(S)	x1	2081x788x3	1/1
(Z)	x1	2065x60x18	1/1

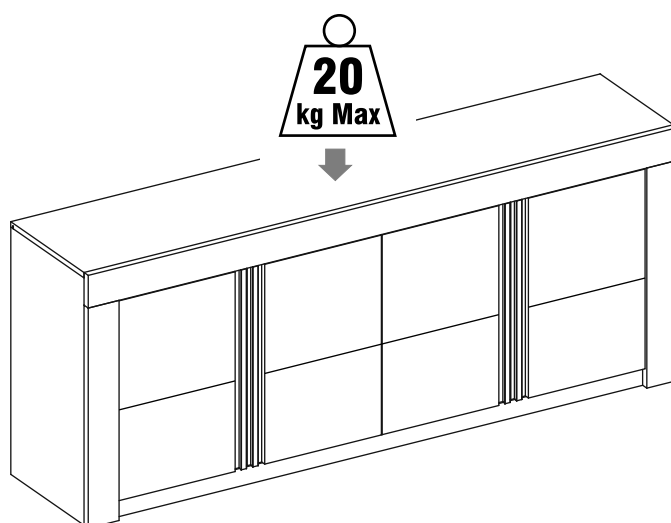

301 x32



8x30

302 x16



3,5x16

354 x4



8x40

306 x16



325 x7



326 x14



419 x1

352 x12



356 x12



M4x25

327 x1



L.50mm

360 x12



331 x1



332 x1



328 x8



421 x8



3,5x18

422 x4



353 x12



5x25

350 x1



303 x25



15

313 x25



cod.807500754

cod.807500765

408 x2



409 x2



x2

cod.807500748

368 x2



H.4

364 x2



H.8

x2

cod.807500617

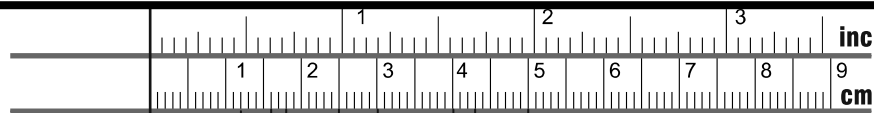

352



302



332



356



301



354





313



327

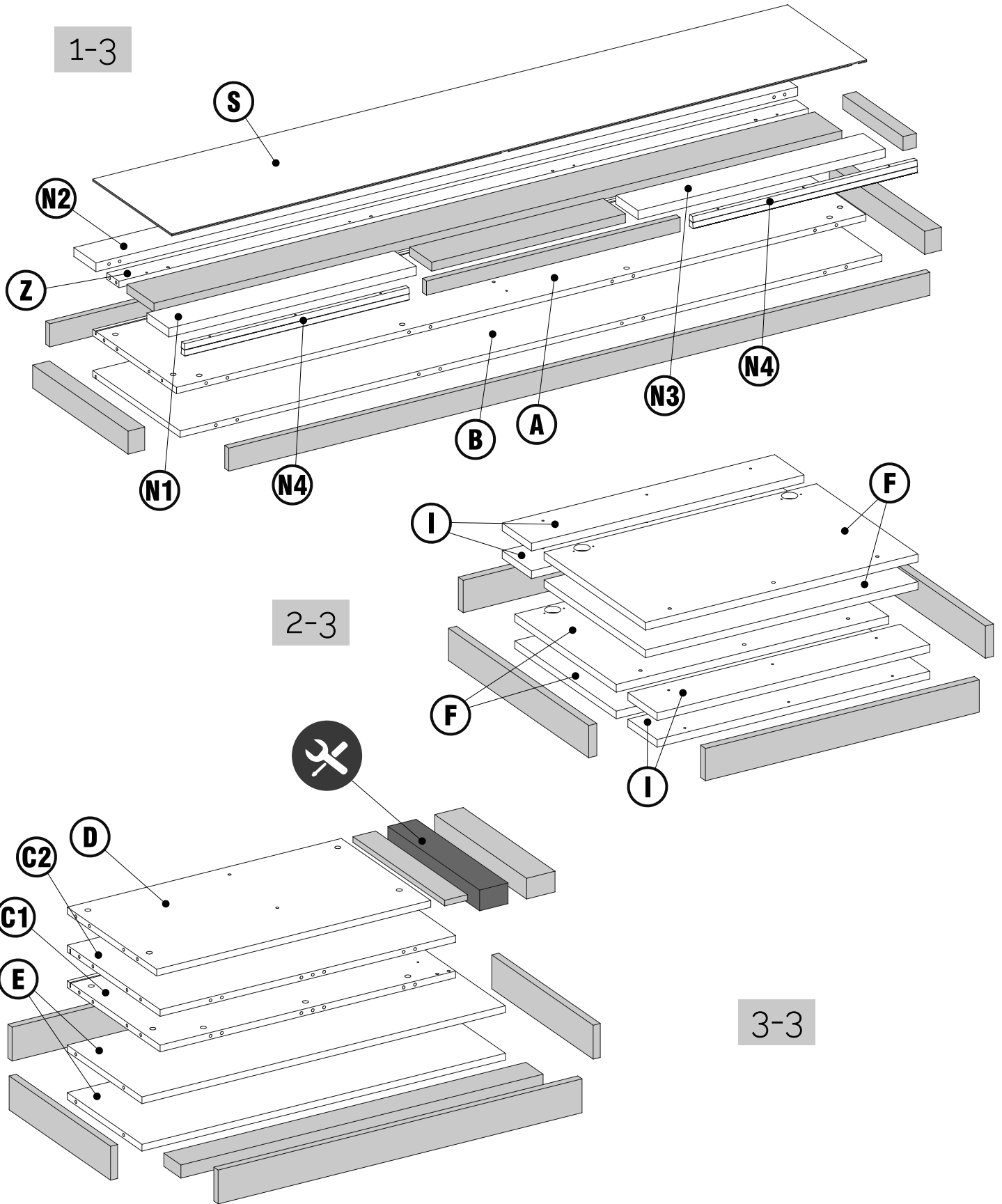



Package 1/3 Kg.35 Package 2/3 Kg.20 Package 3/3 Kg.24	Package total  3 colis
---	---

UTILISER UN CHIFON
DOUX LEGEREMENT
HUMIDIFIE' NE PAS
UTILISER DE PRODUITS
DETERGENTS OU
ABRASIFS



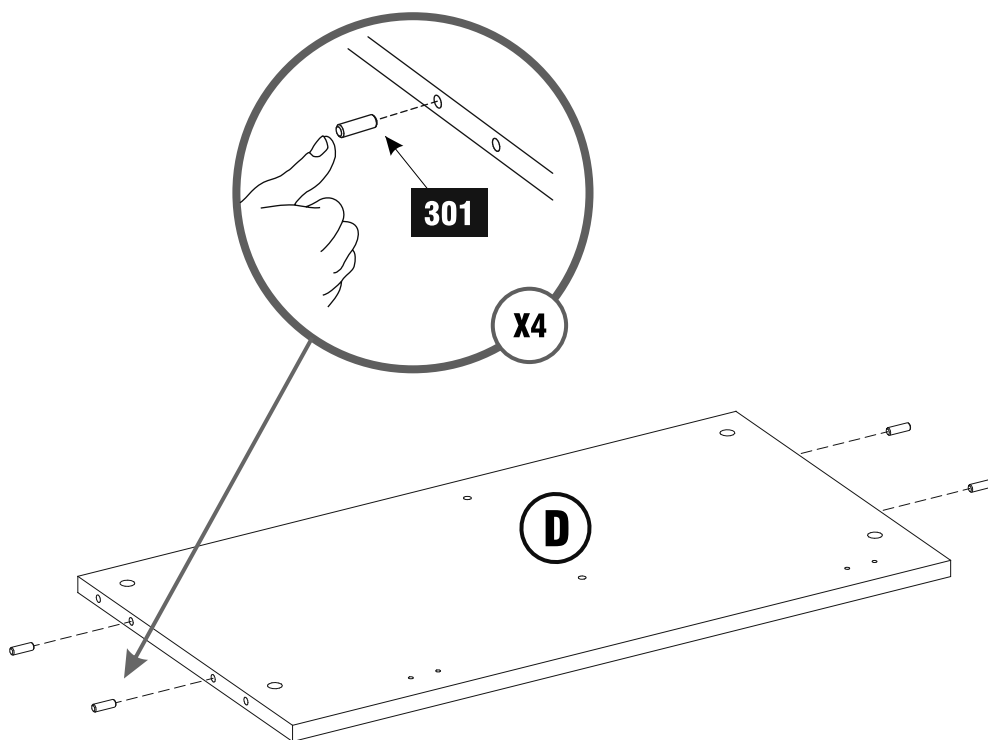
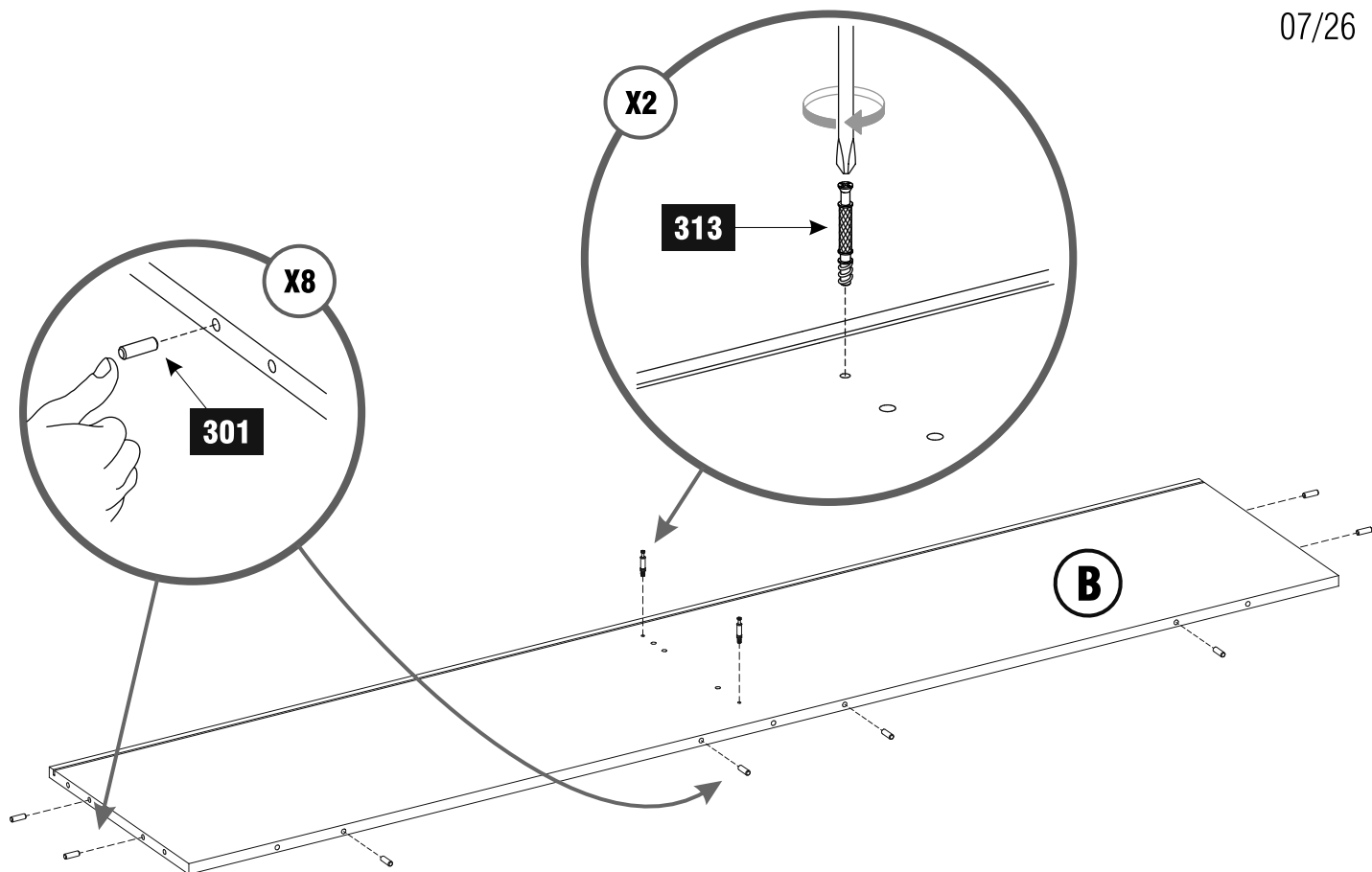

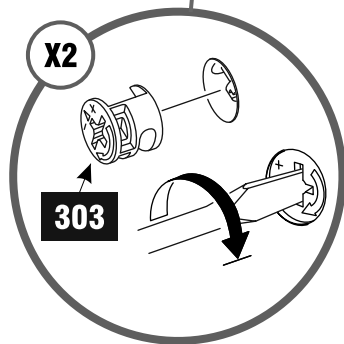
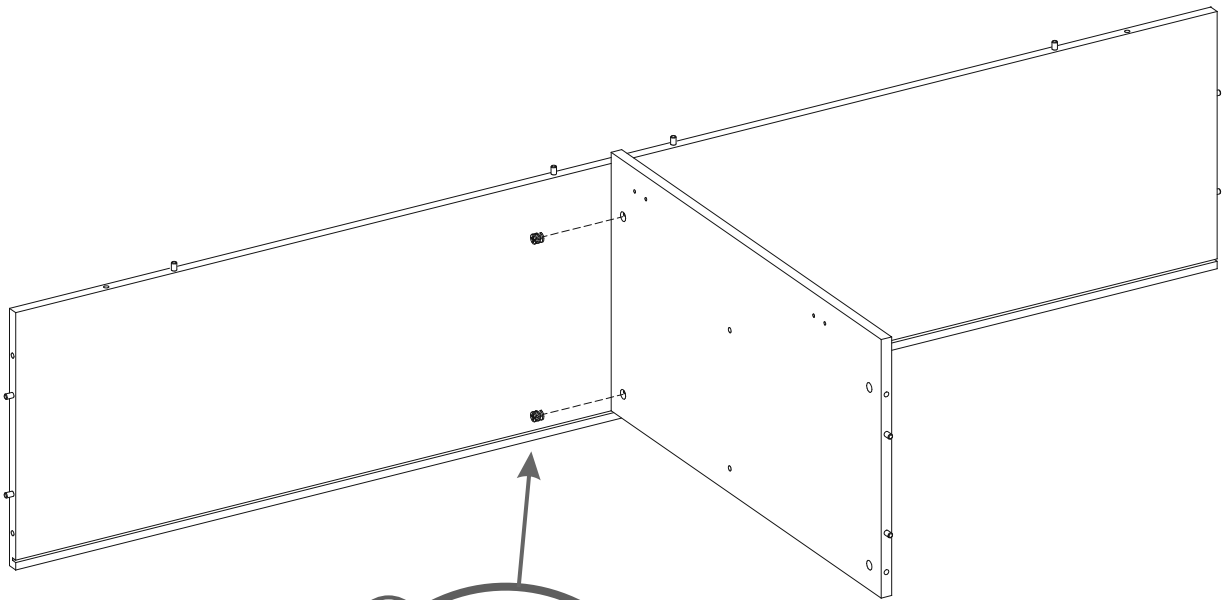
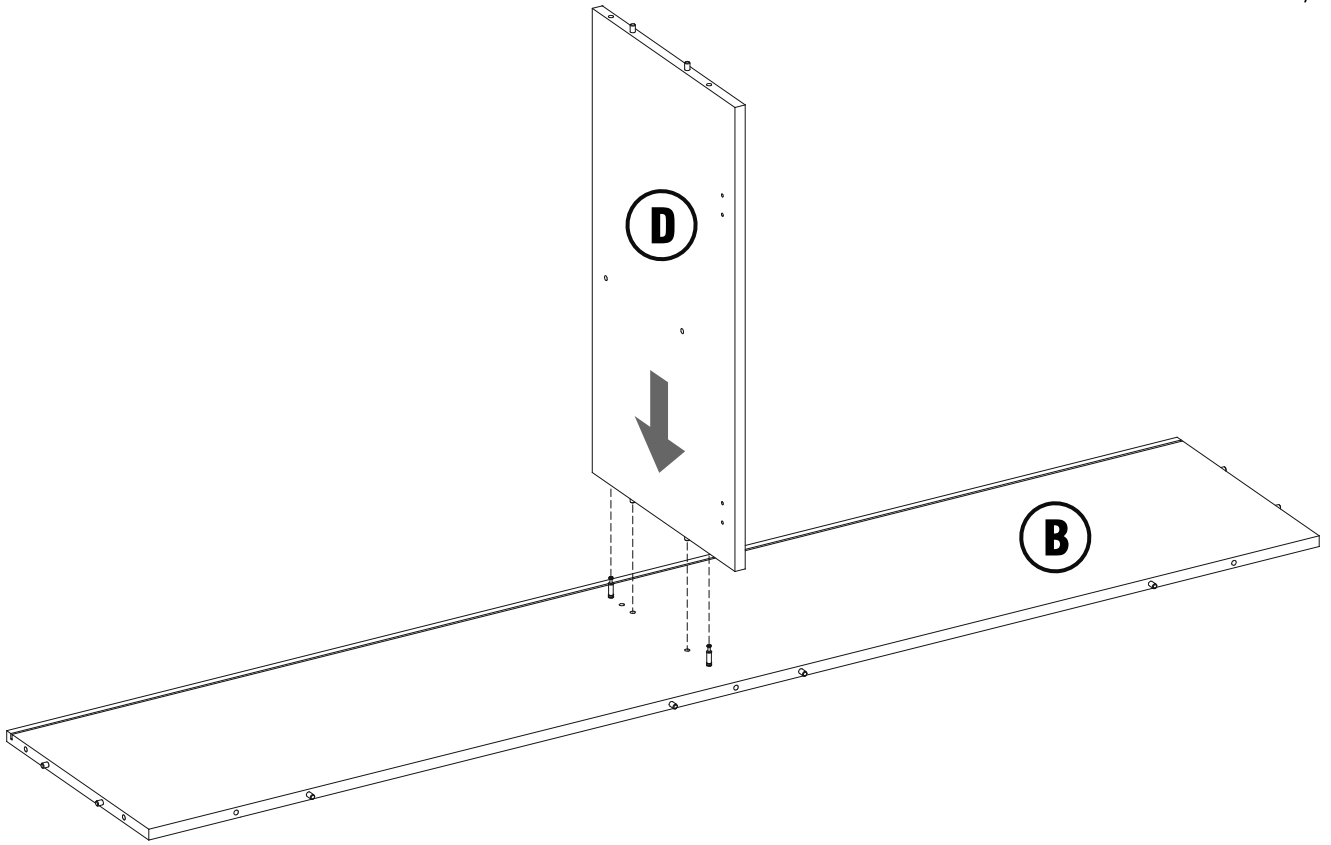

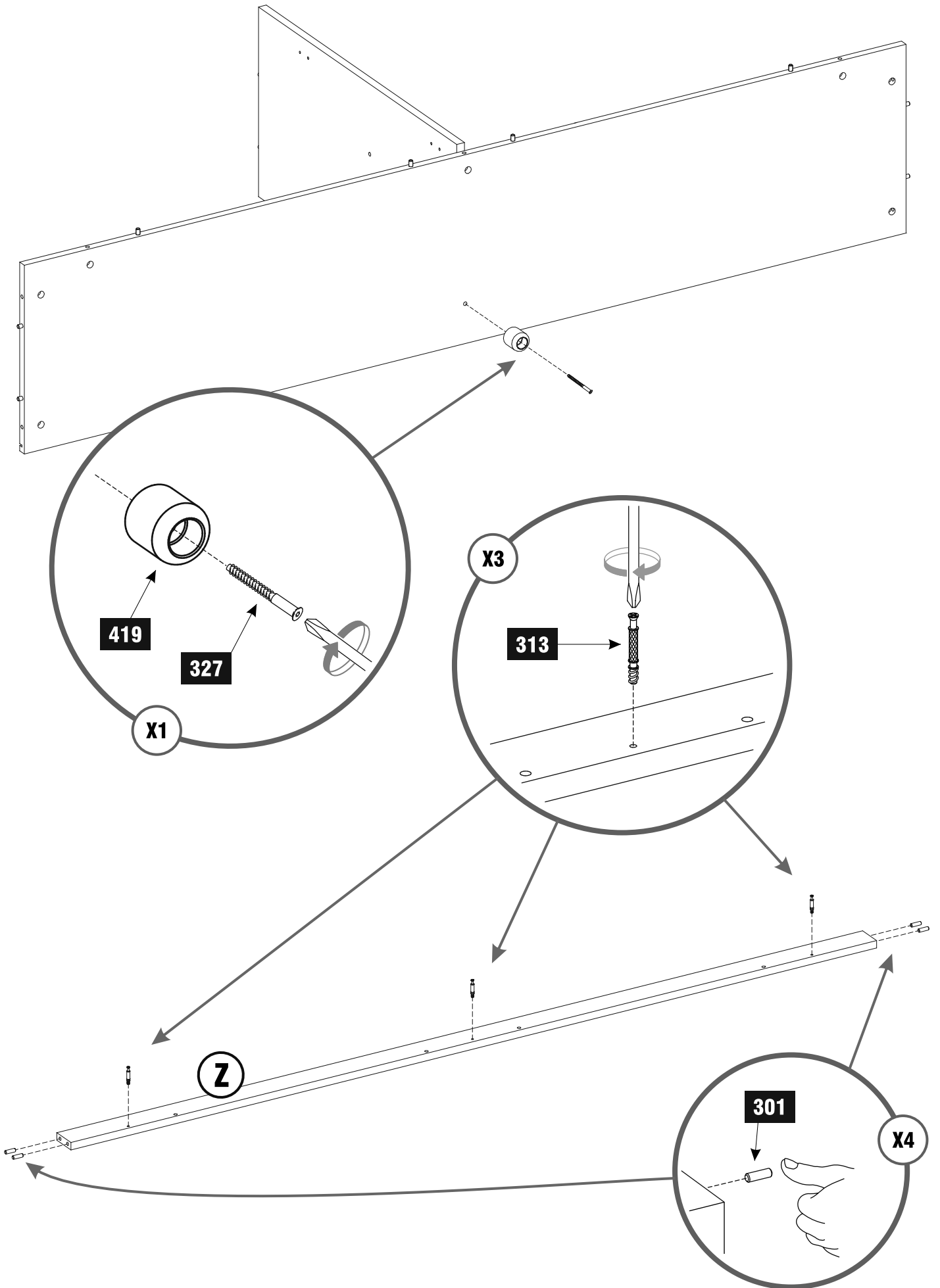

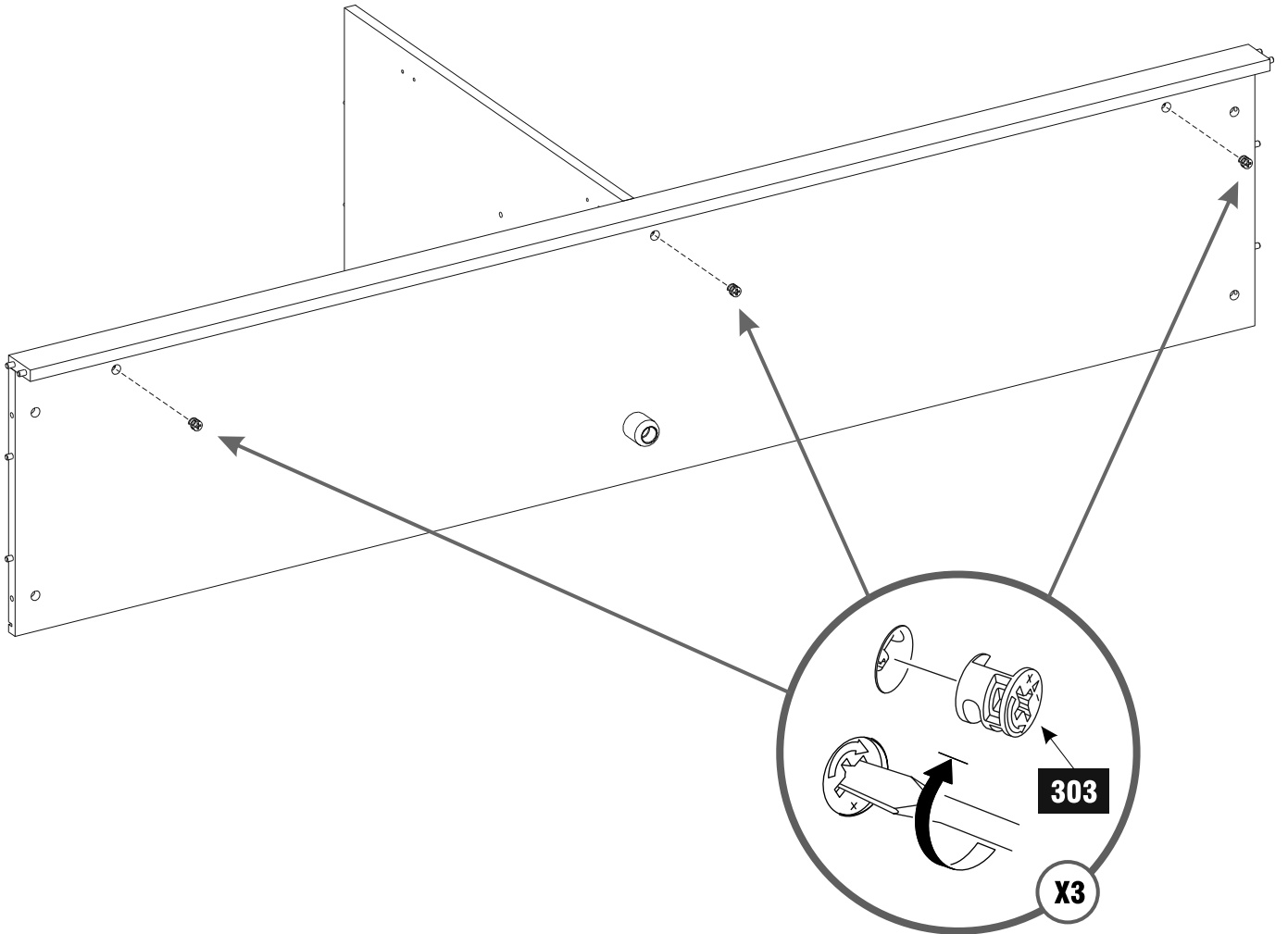
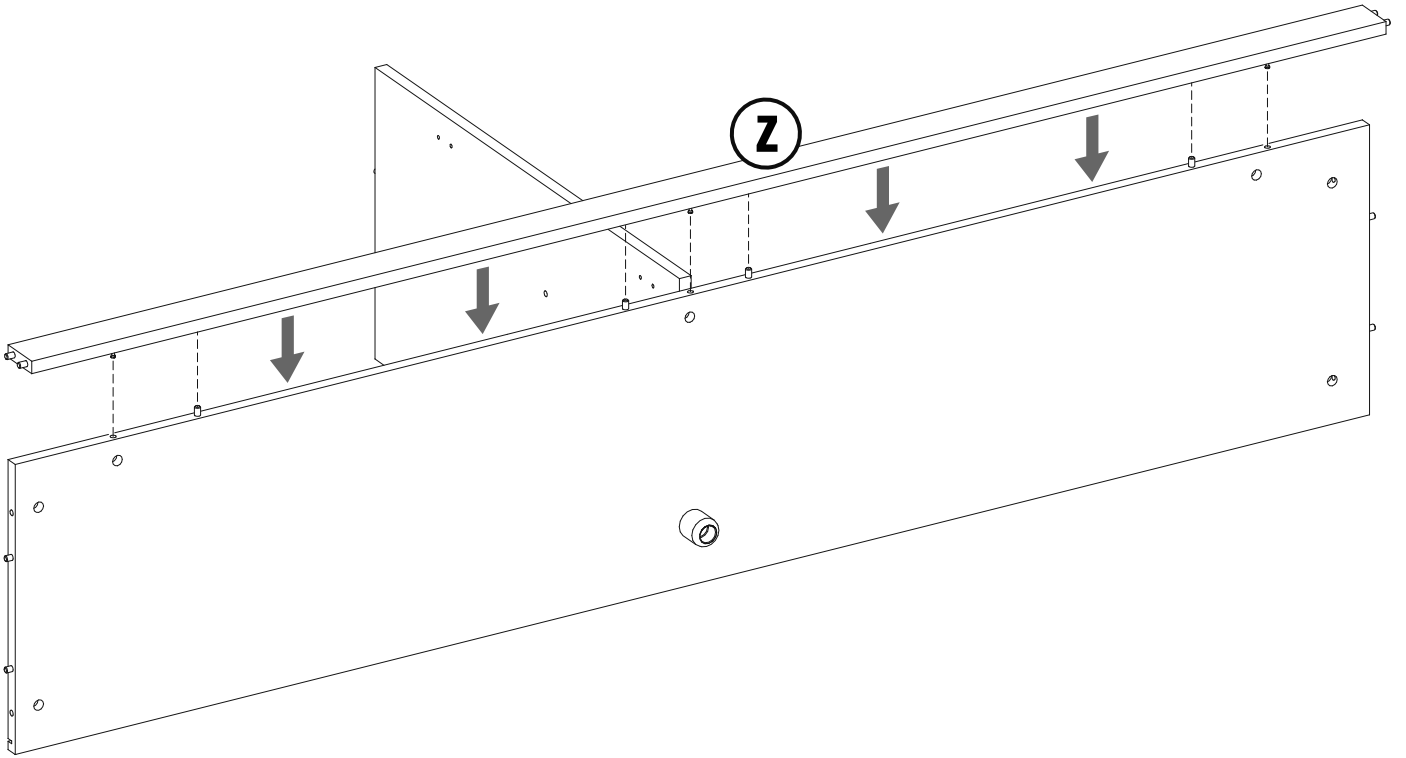

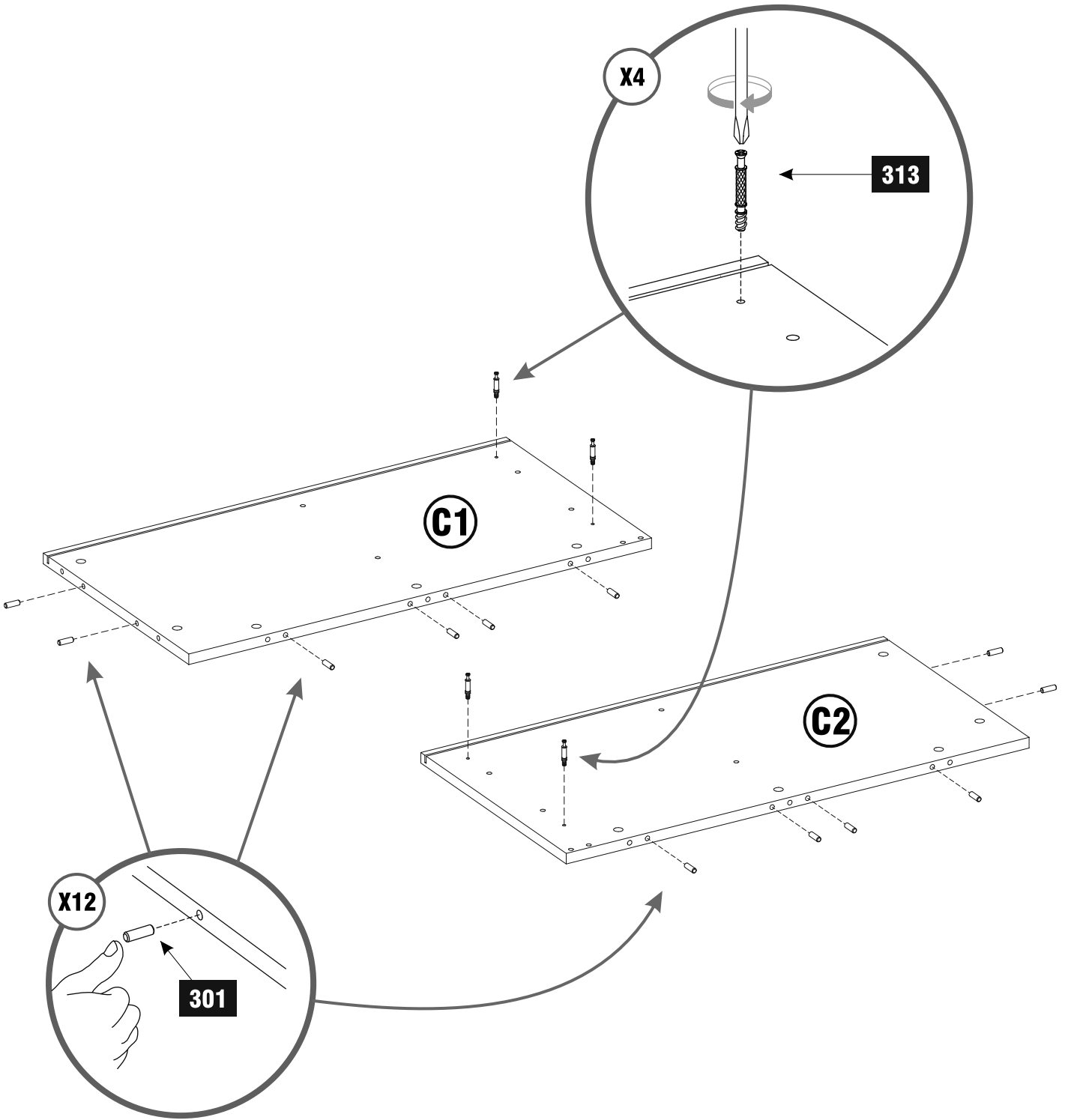

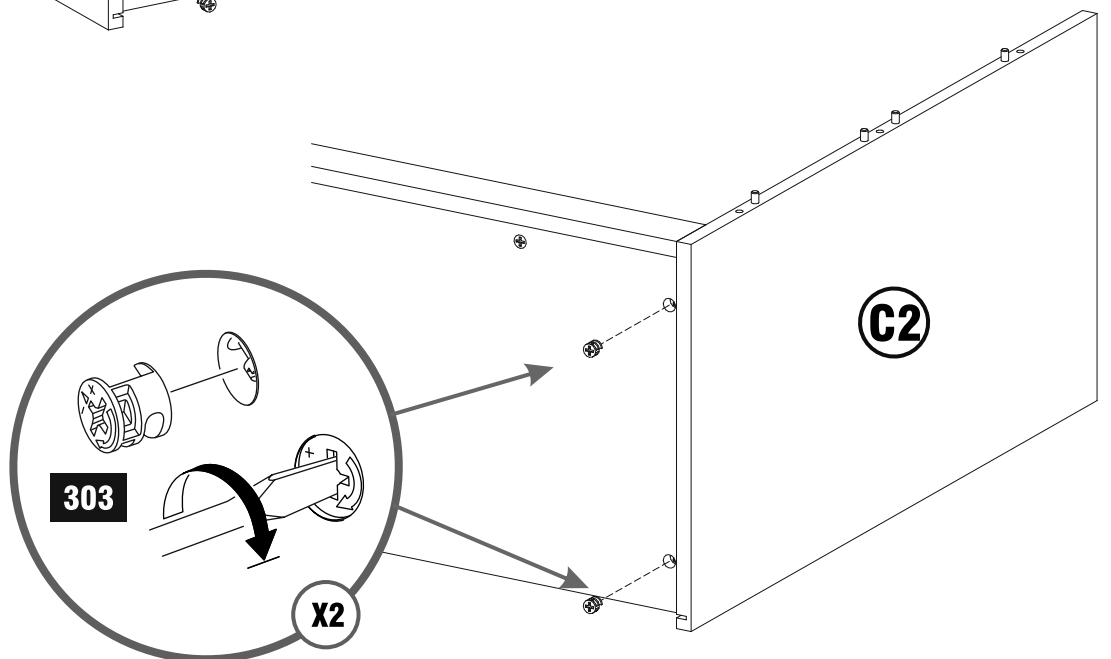
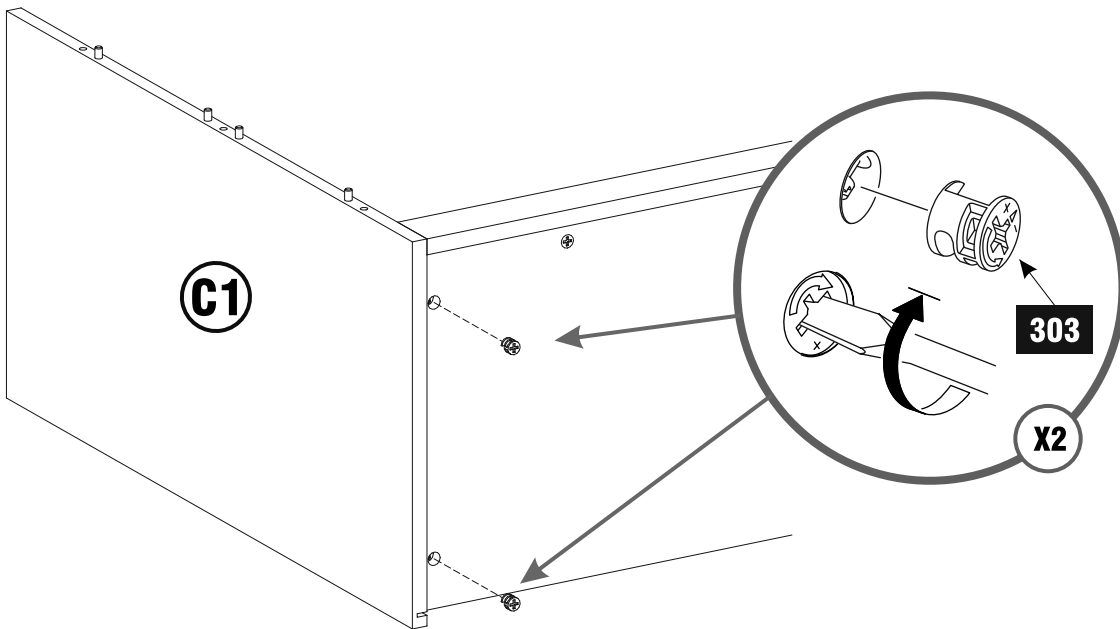
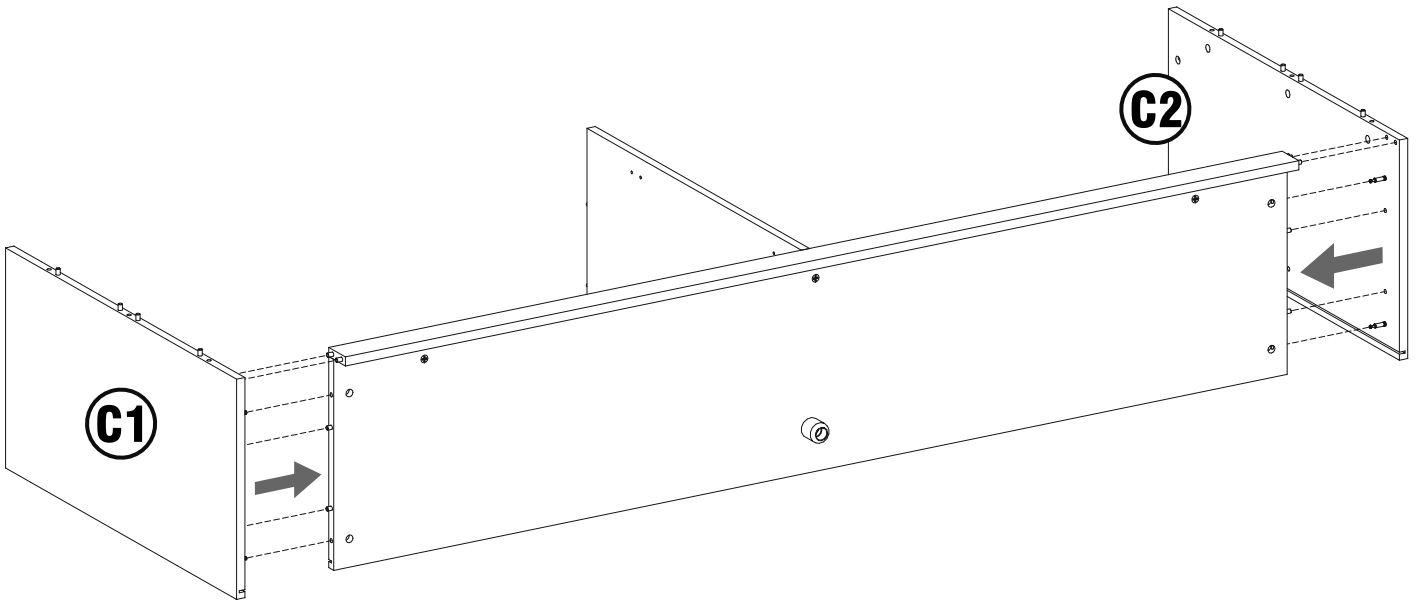

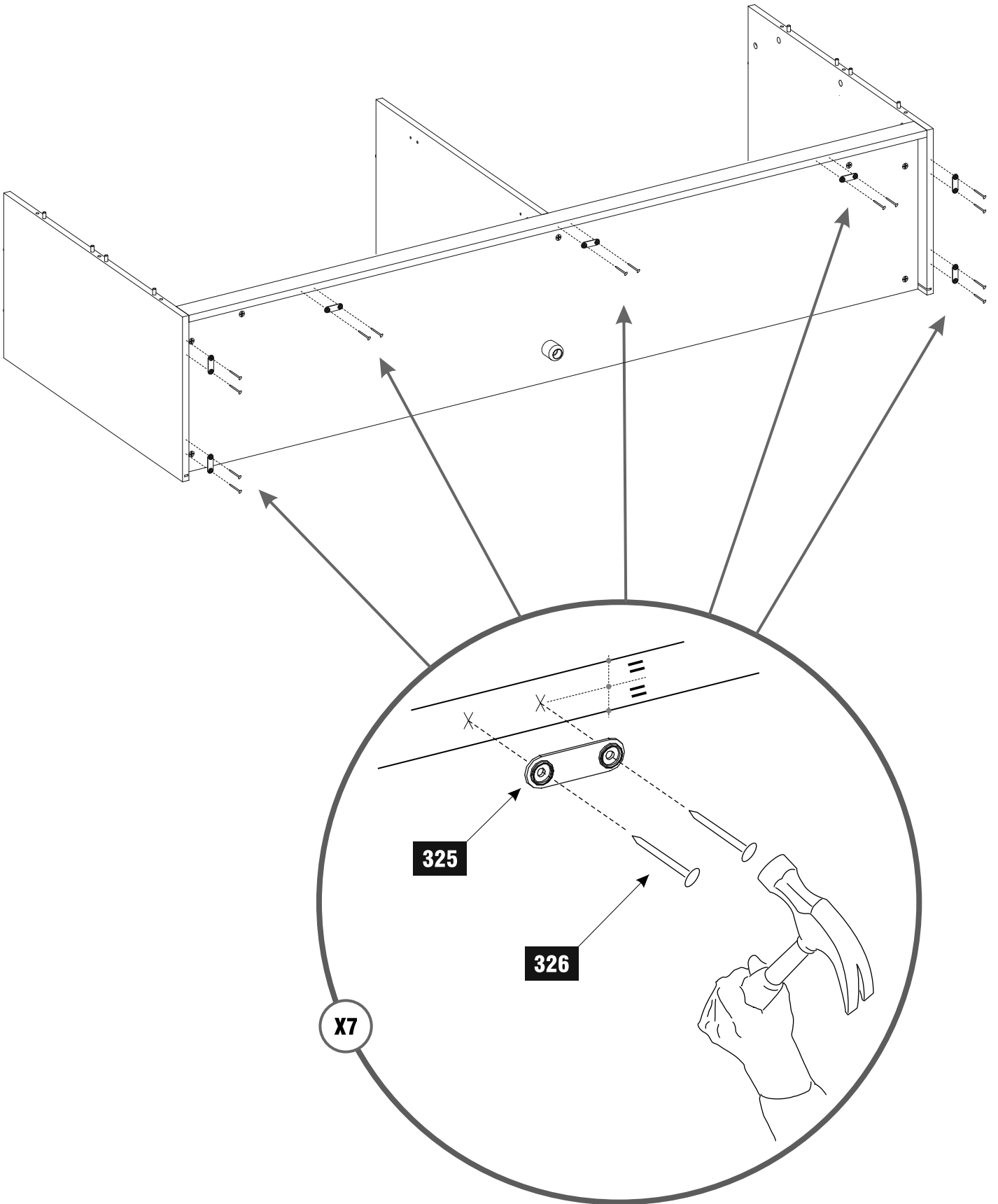

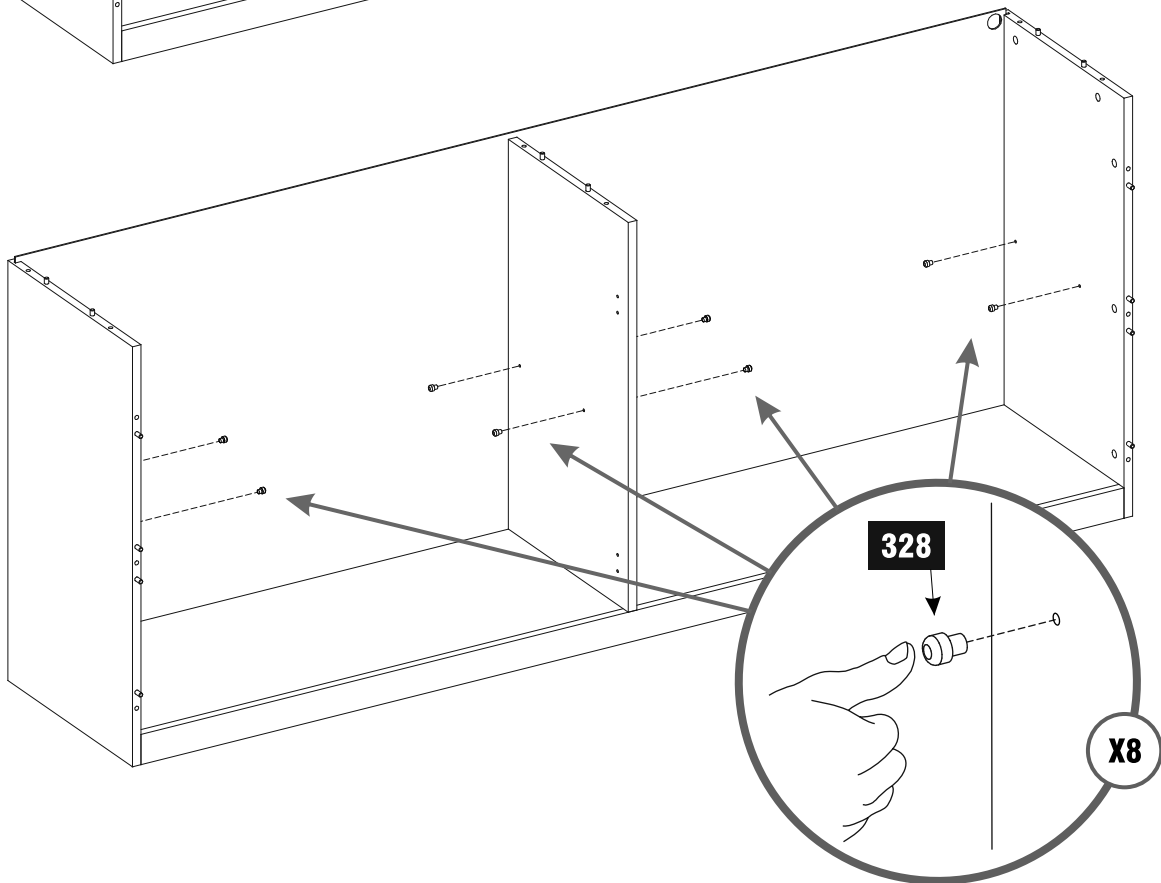
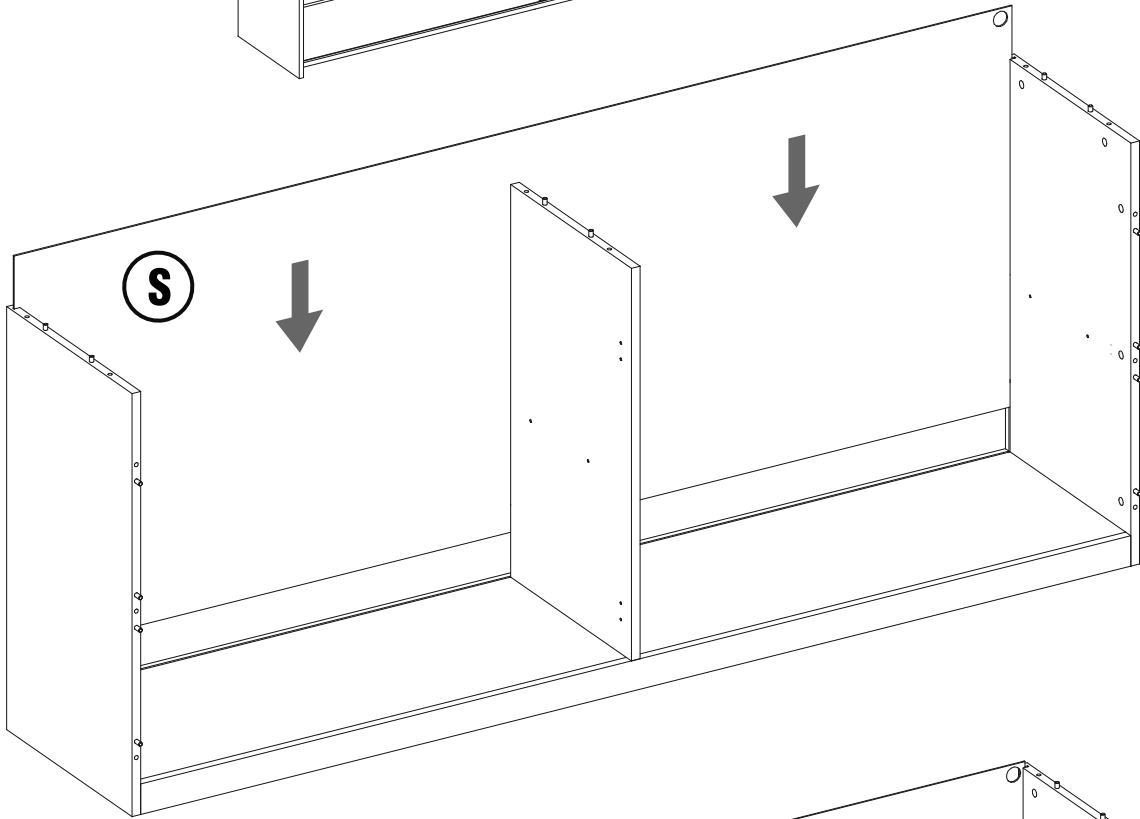
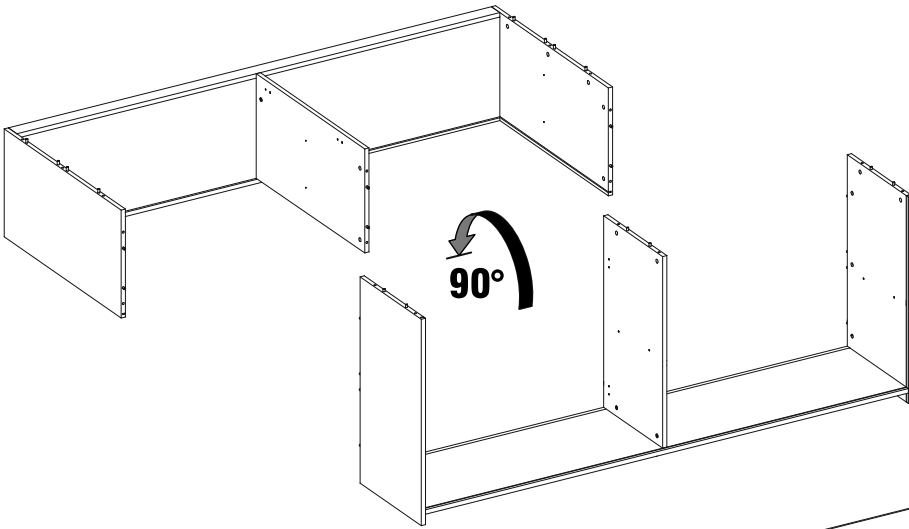

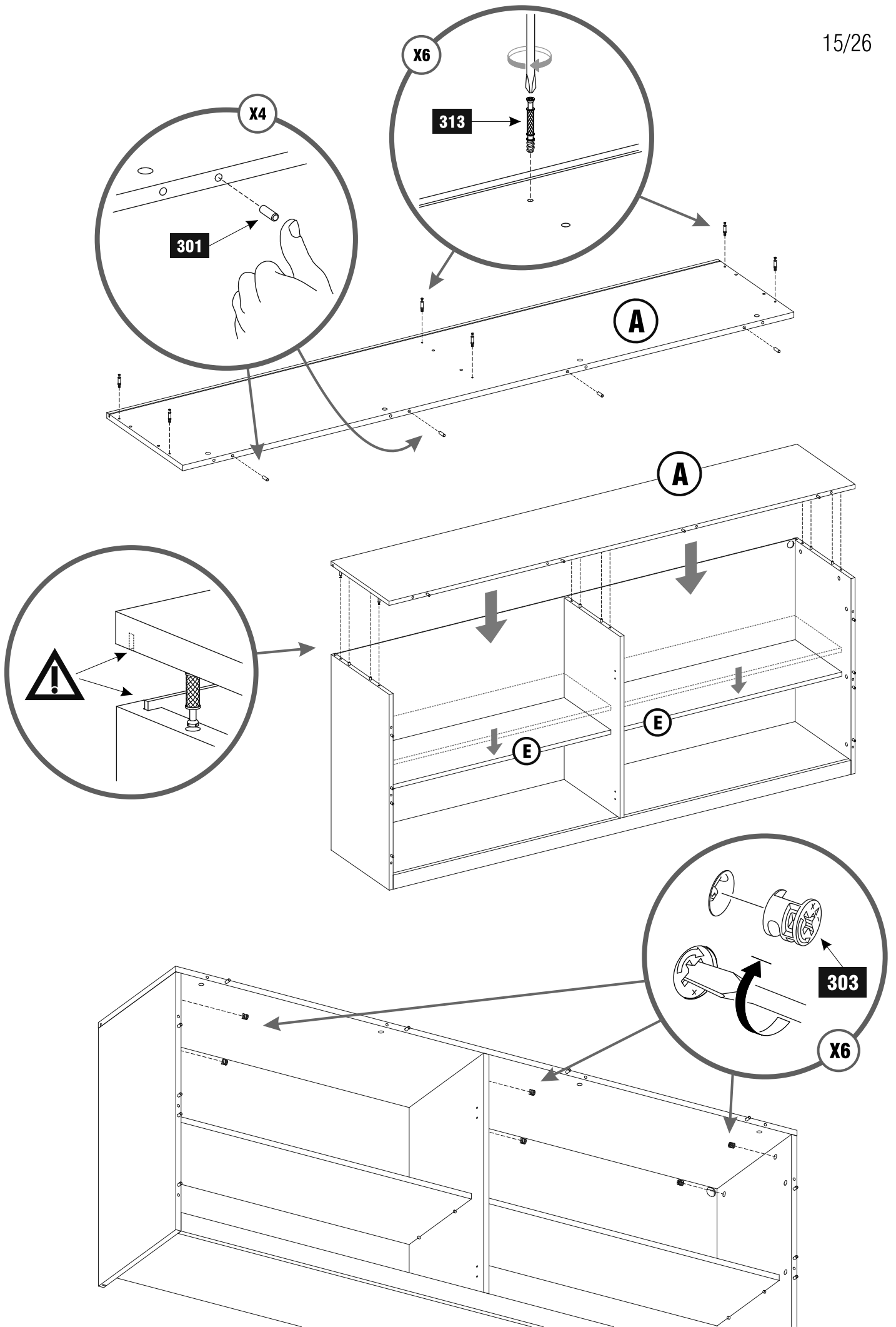

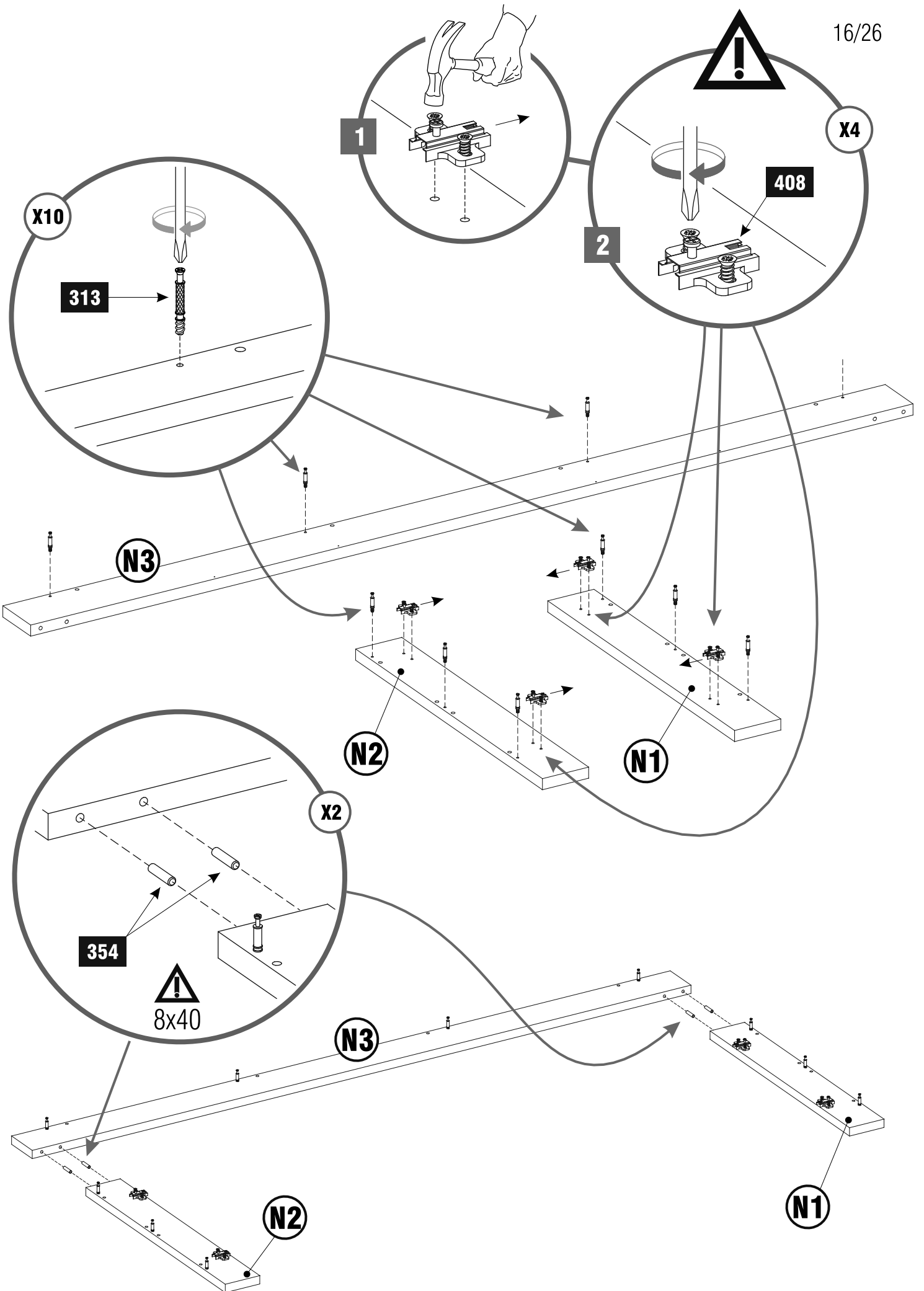

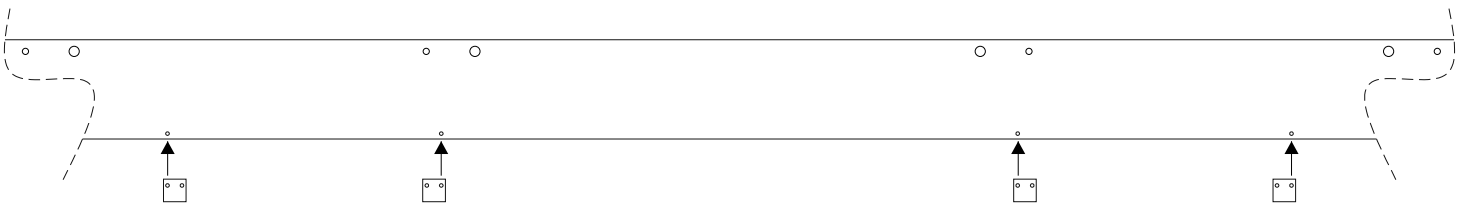
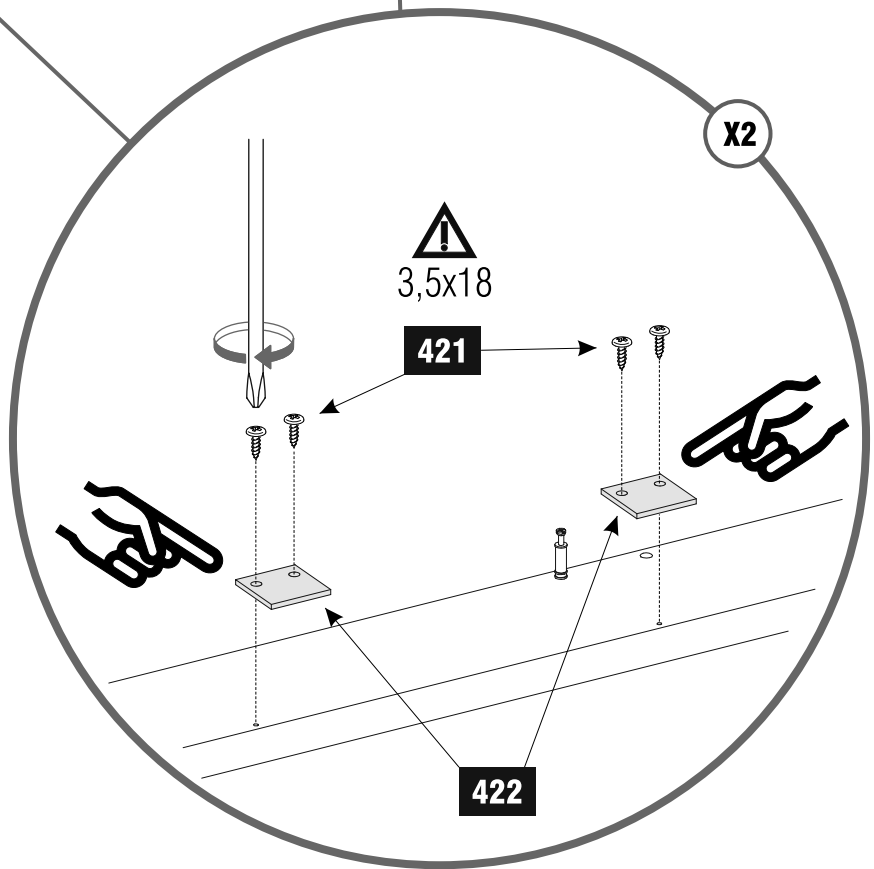
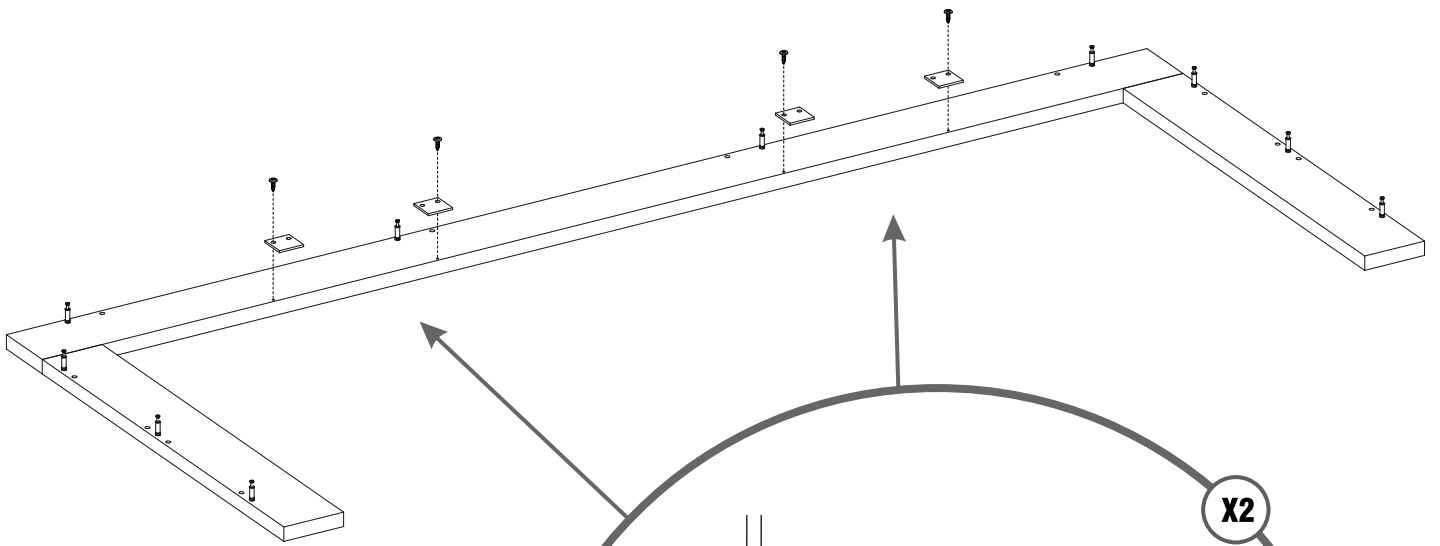

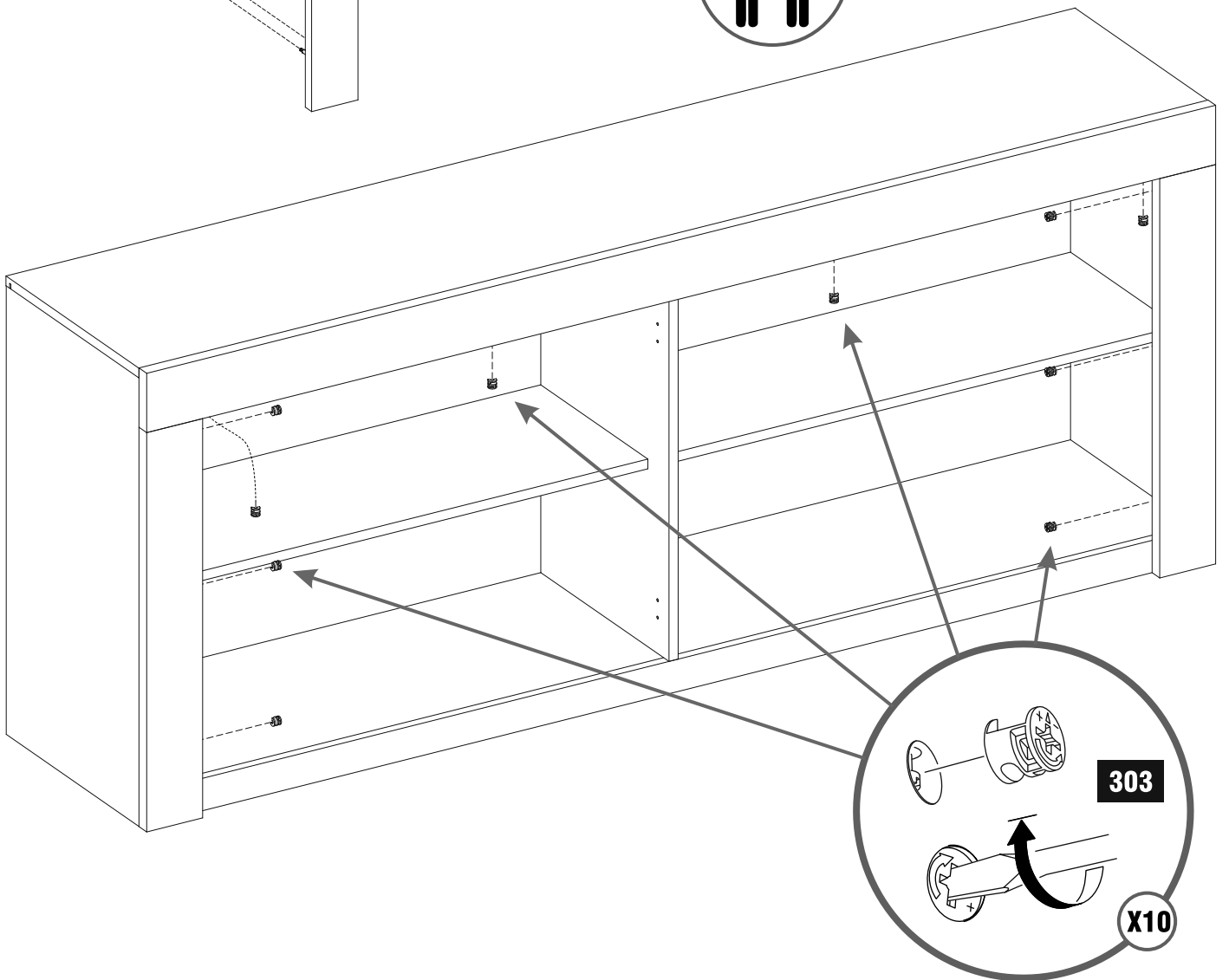
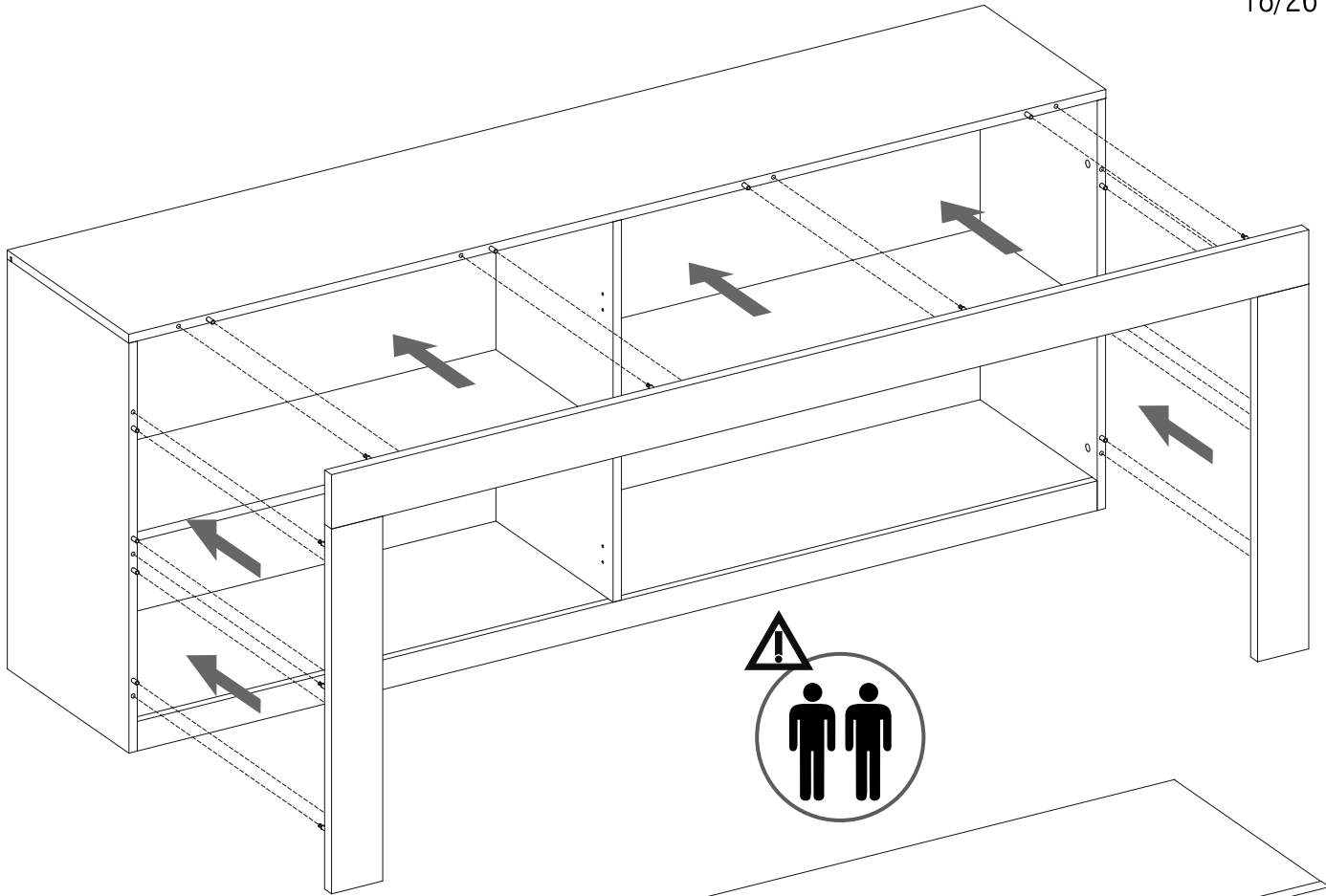

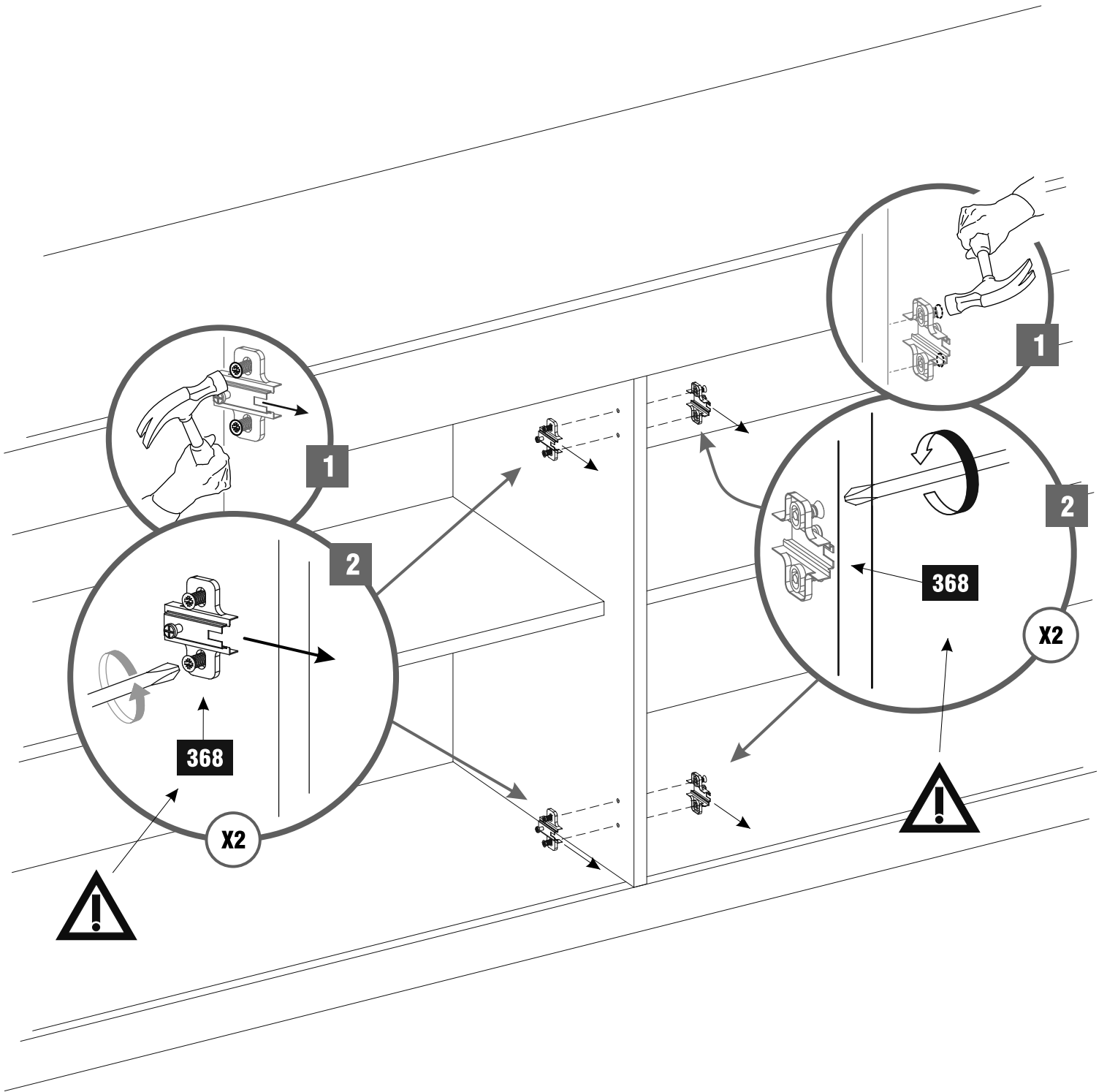



A=B

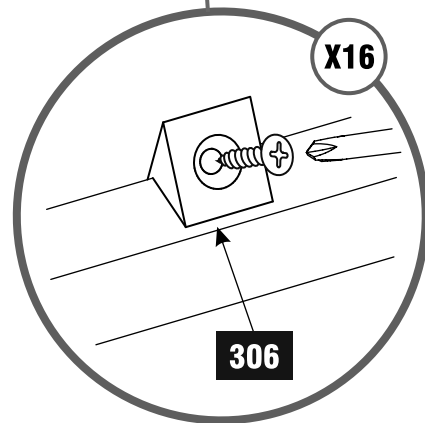
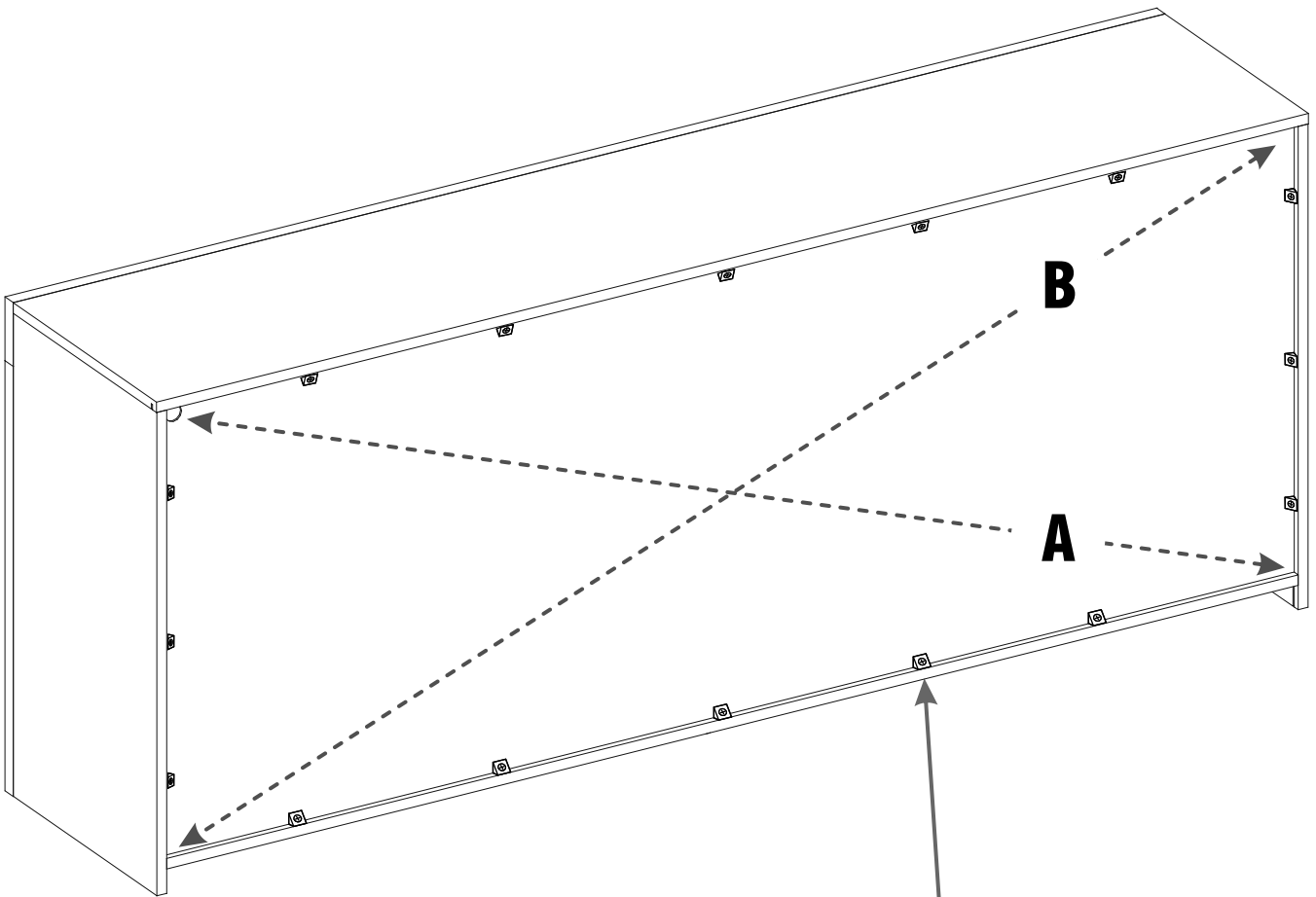
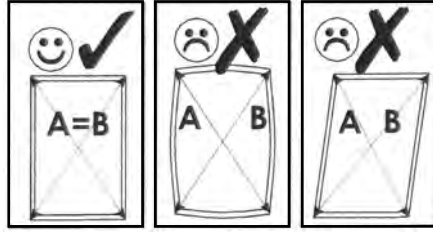

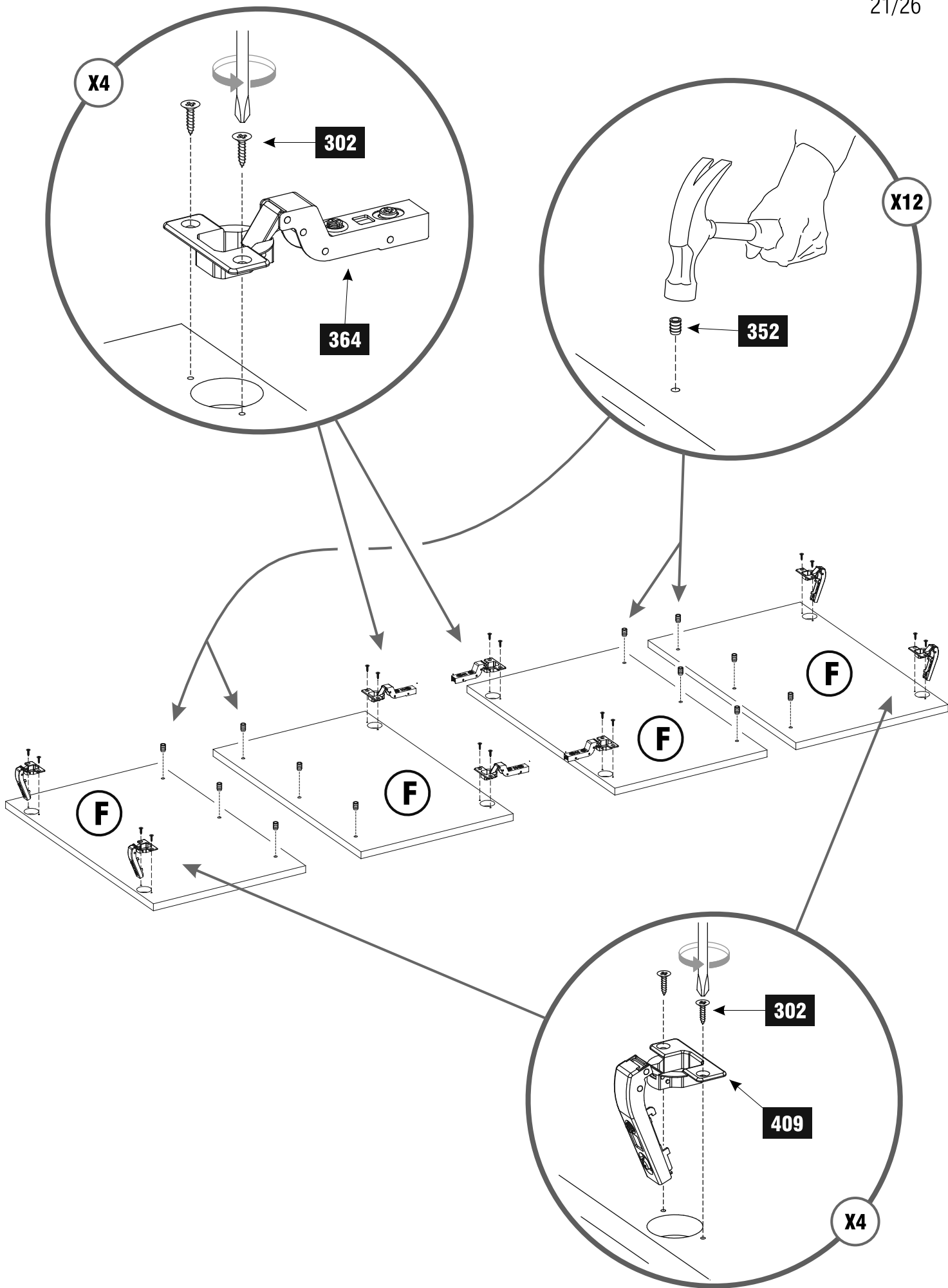

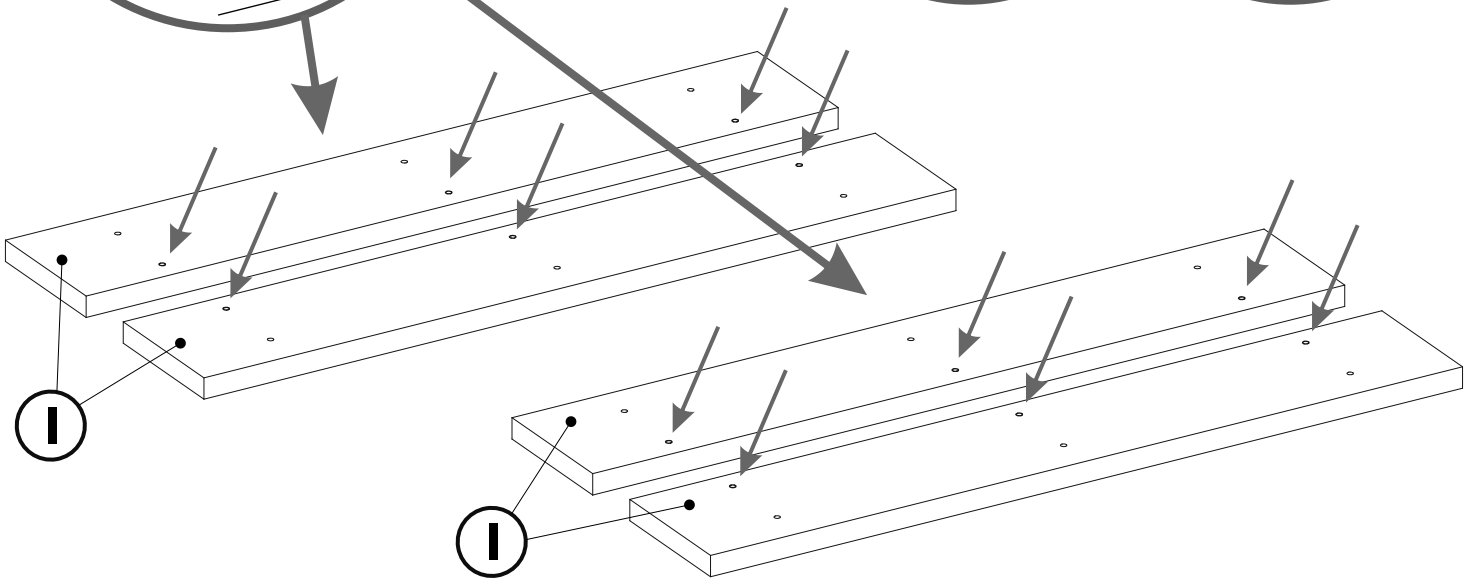
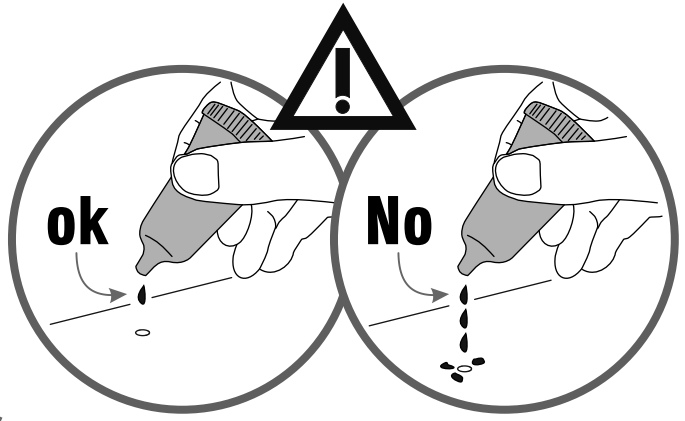
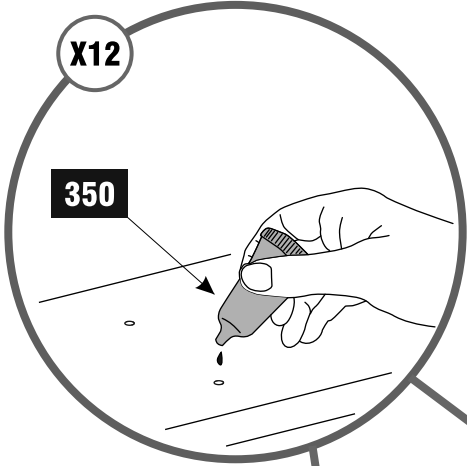
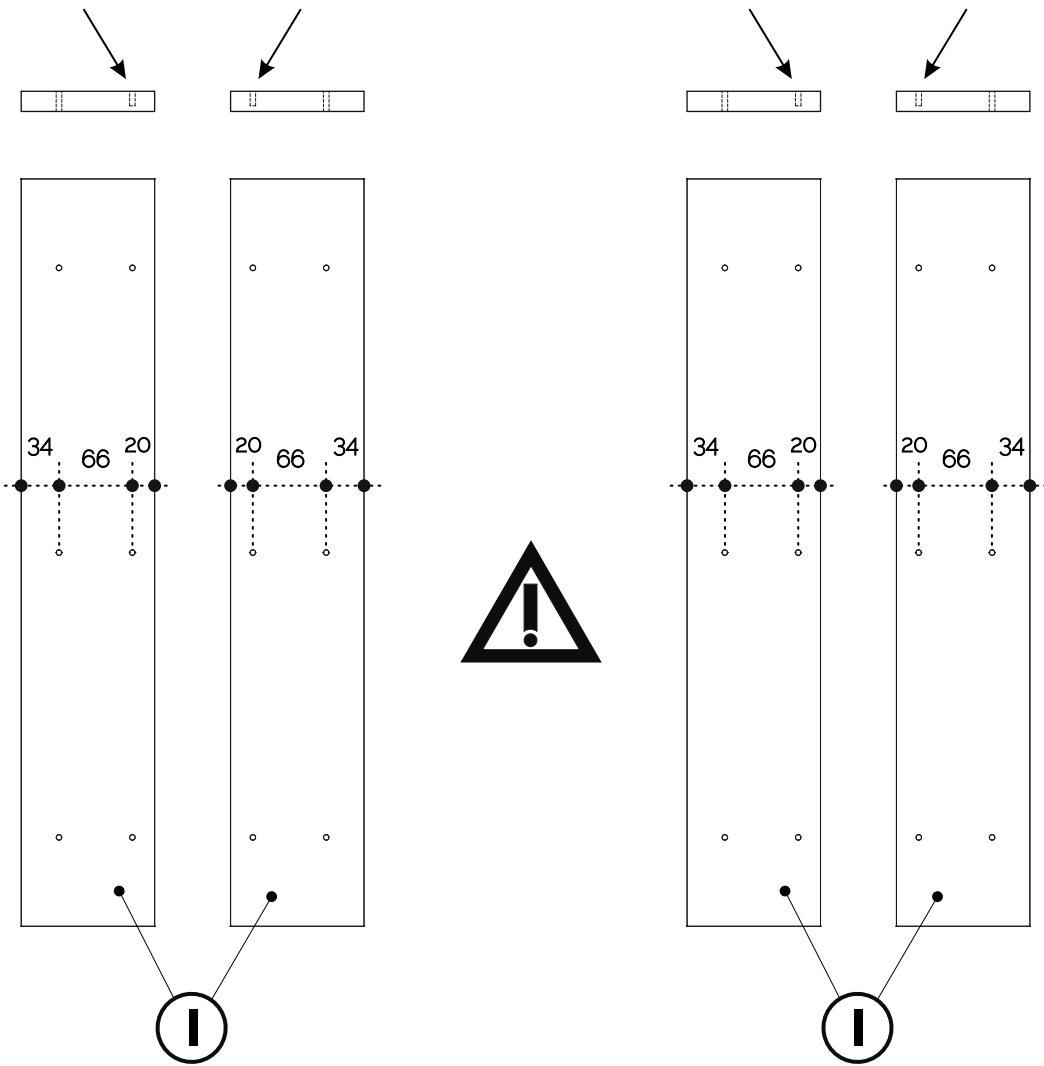

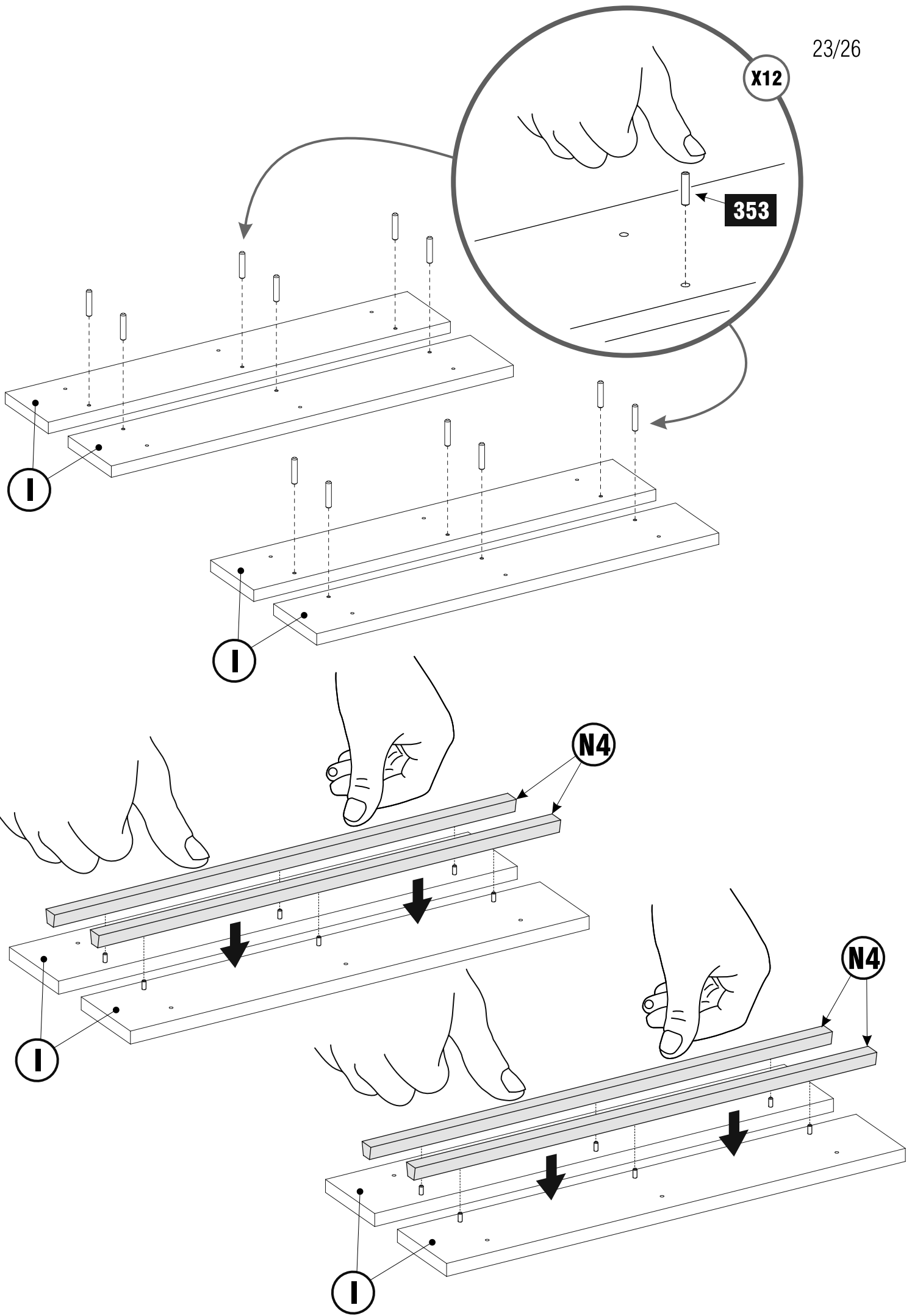

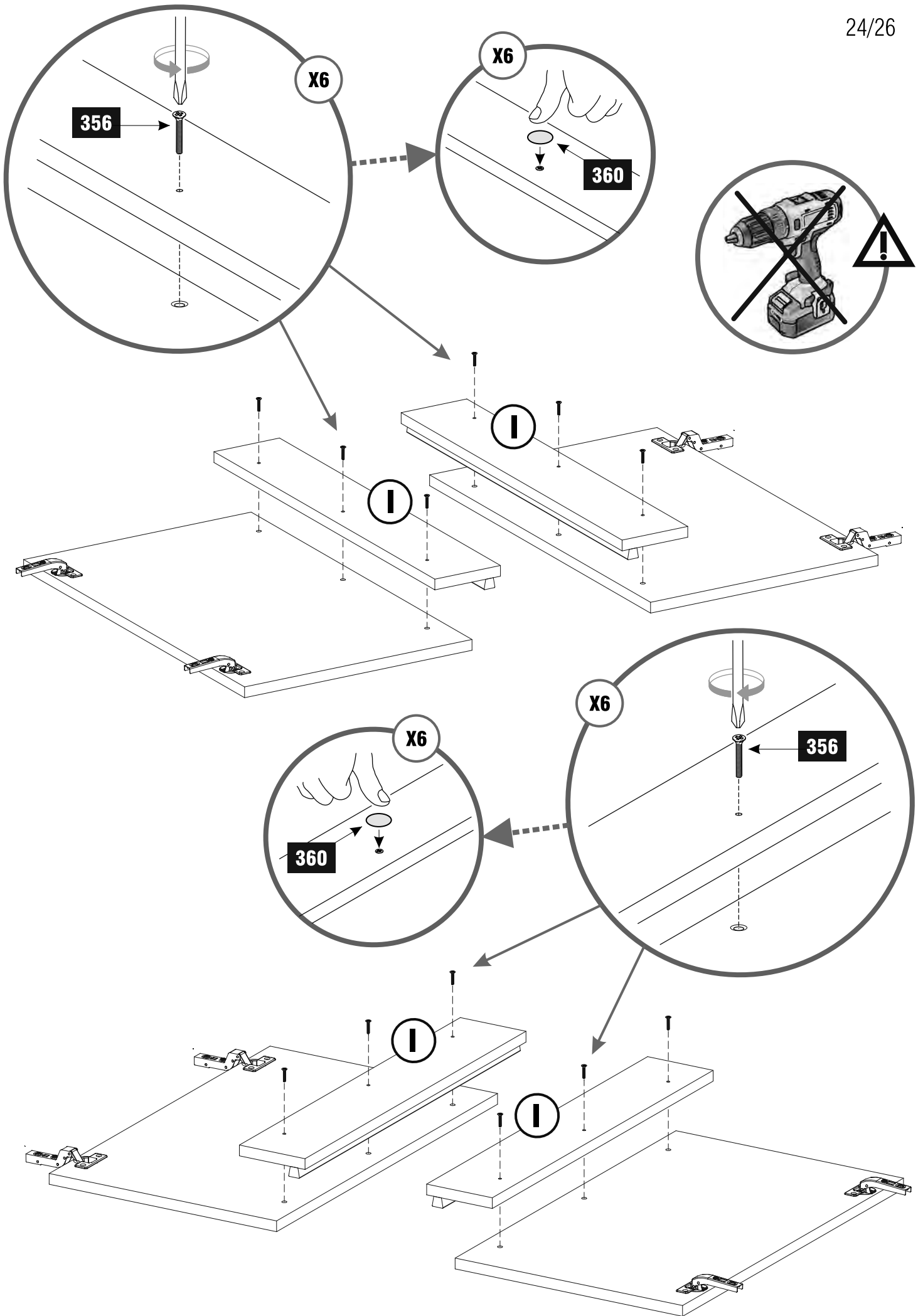

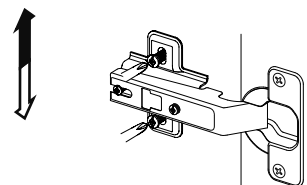
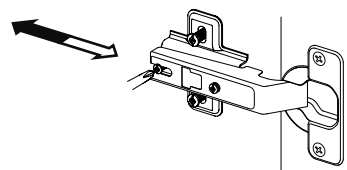
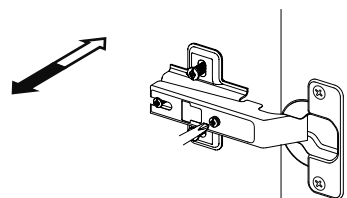
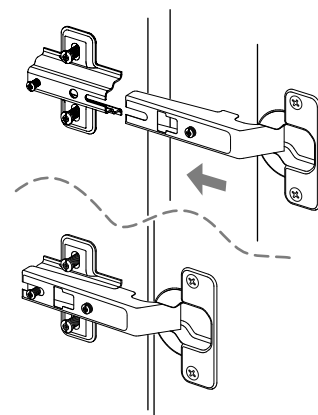
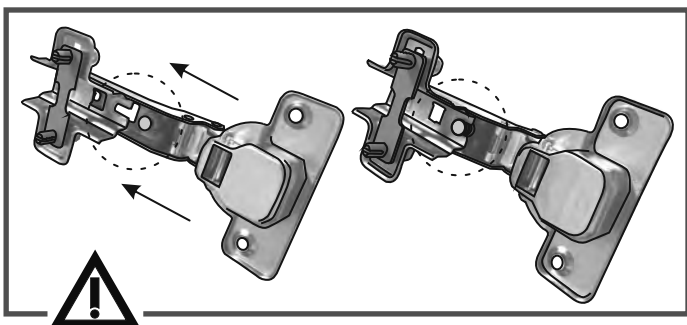
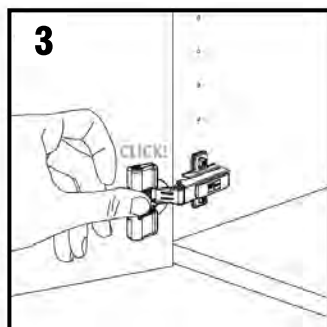
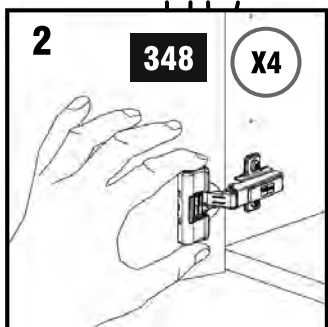
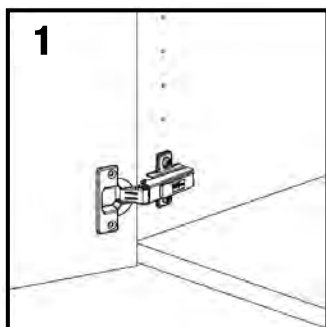
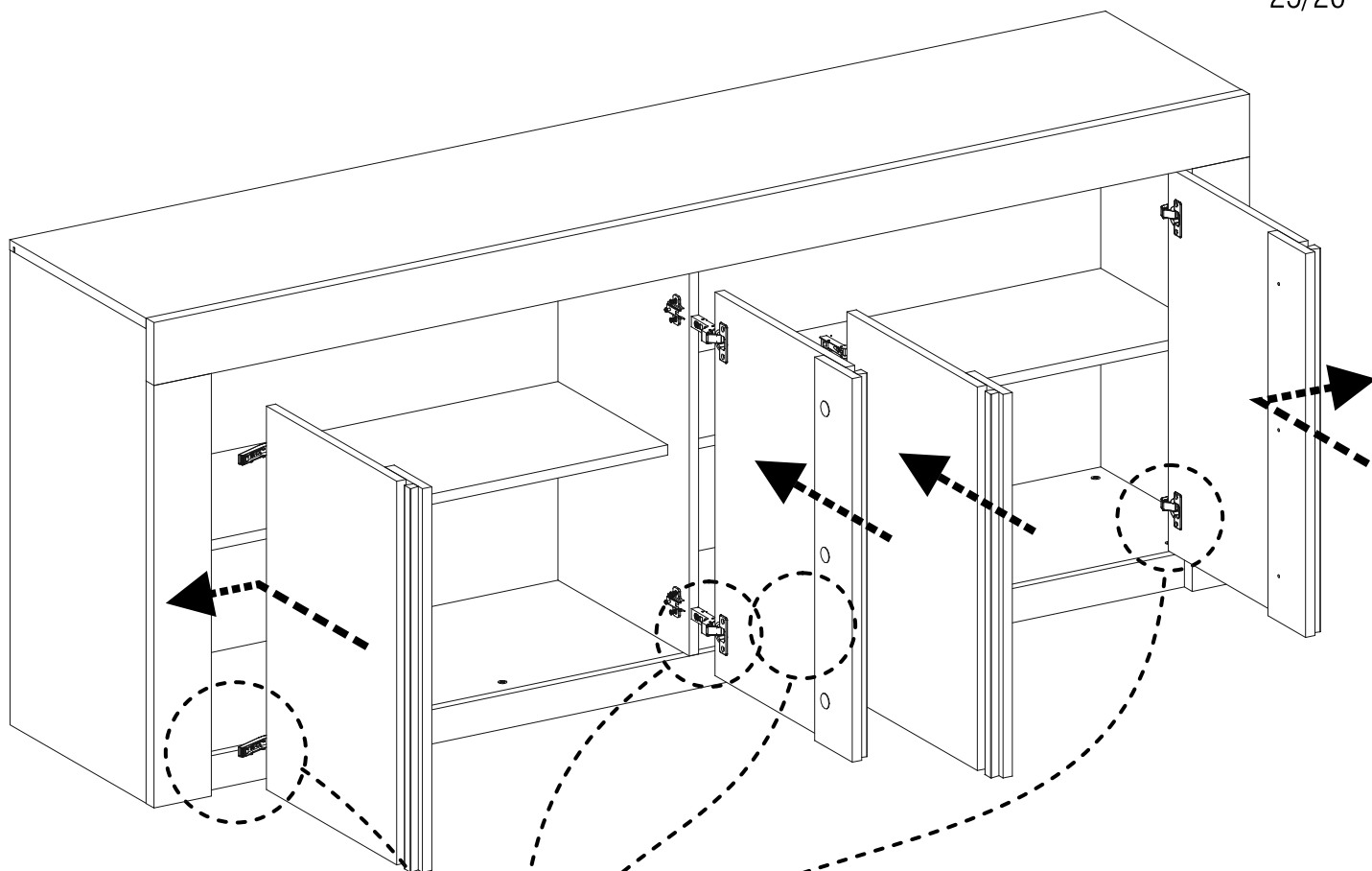

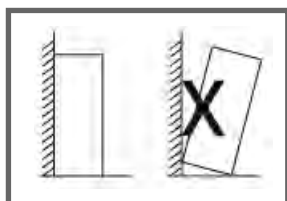
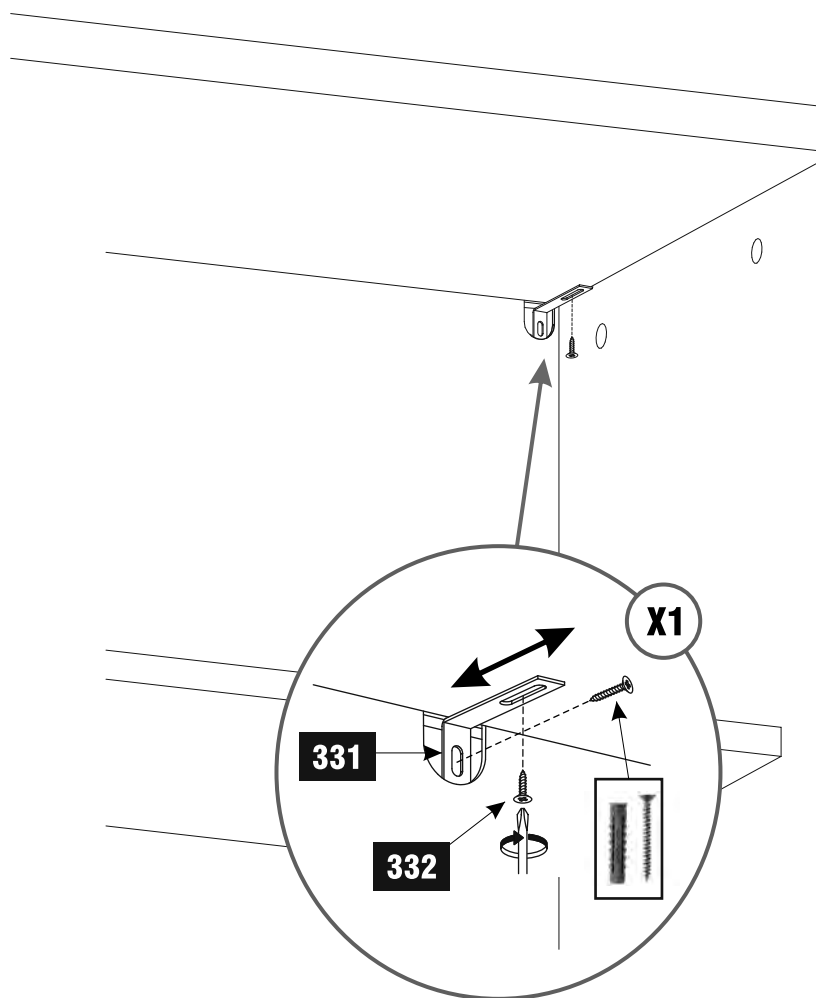

- FR** Pour votre sécurité: Fixation du meuble au mur. Attention, la fixation doit être réalisée par une personne compétente car cela nécessite des chevilles adaptées à la nature de votre mur. Les fixations ne sont pas incluses.
- GB** For your own safety: Attach the furniture to the wall. Important: The furniture must be attached by a qualified person using dowels that are suited to the type of wall. Fixing devices for the wall are not included.
- D** Für ihre Sicherheit: Befestigung des Möbelstücks an der Wand. Achtung, die Befestigung muss von einem Fachmann vorgenommen werden, weil sie an die Wand angepasste Dübel erfordert. Beschläge für die Wandbefestigung sind nicht beige packt.
- E** Para su seguridad: Fijación del meuble a la pared. Ojo! La fijación deberá llevarla a cabo una persona competente ya que necesitará unos tacos adaptados a tipo de pared. No se incluyen los dispositivos de fijación.
- PT** Para a sua segurança: Fixação do móvel na parede. Atenção, a fixação deve ser efectuada por uma pessoa competente, pois exige a utilização de cavilhas adaptadas à natureza de parede. Ferragens não incluídas.
- I** Per la vostra sicurezza: Fissaggio del mobile alla parete. Nota bene, il fissaggio deve essere eseguito da personale specializzato, utilizzando tasselli adatti alla parete. I tasselli per il fissaggio alla parete non sono inclusi.
- HR** Za vašu sigurnost: element privrstiti za zid. Važno: element mora biti privršen od strane kvalificiranih osoba, koristeći adekvatne vijke za vaš tip zida. (Knauf-cigla i slino). Montažni vijci nisu uključeni u samom elementu.