

<b>AAx4</b>	
<b>BCx4</b>	
<b>DLx2</b>	
<b>CAx6</b>	
<b>ECx6</b>	
<b>DAx20</b>	
<b>NAx4</b>	
<b>NDx4</b>	
<b>IJx4</b>	
<b>NKx30</b>	
<b>DBx3</b>	
<b>QMx2</b>	
<b>ITCx2</b>	

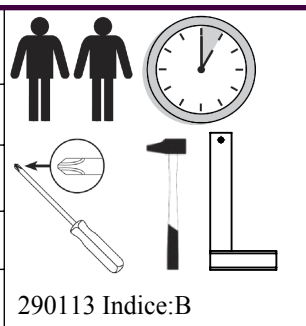

290113 Indice:B

# 6091

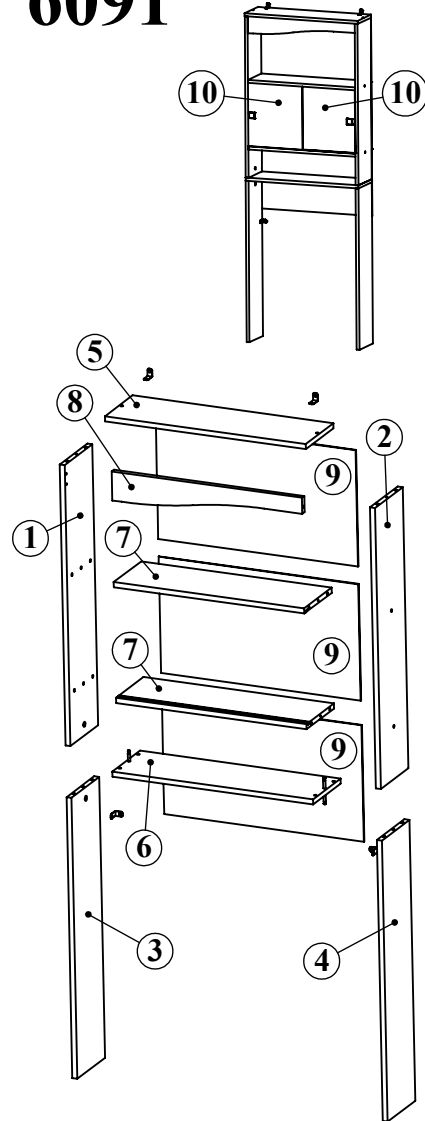

- Contrôlez le contenu de votre colis avant de procéder au montage.  
 - Ne détériorez pas l'emballage, il vous sera utile pour protéger les éléments des coups ou rayures pendant le montage.  
 - Assemblez ensuite le meuble en suivant l'ordre défini par la numérotation.  
 - Conservez cette notice et en cas de problème contactez notre service après vente.

- Vermiel de verpakking niet! Na het verwijderen van eventuele nietjes kunt u het op de grond leggen om de planken te beschermen tegen krassen en duwen tijdens het monteren.  
 - Geleef de inhoud van uw pakket te controleren alvorens aan de montage te beginnen.  
 - Steek daarna het meubel in elkaar, de juiste volgorde van de nummering volgend.

- Check the content of your parcel before assembling.  
 - Do not throw away the packing which could be very useful to protect the panels from knocks and scratches when assembling.  
 - Assemble the article following the order of the numbers indicated.



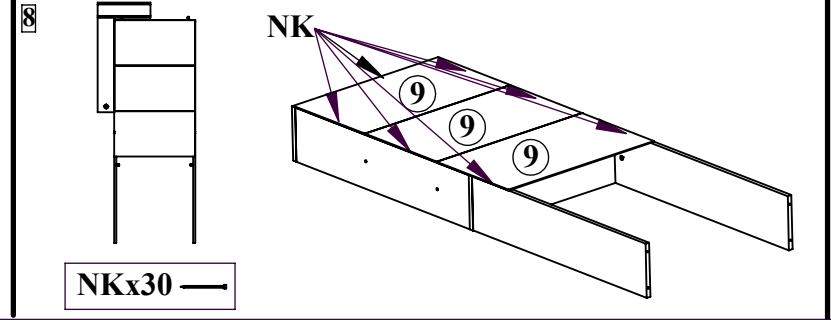
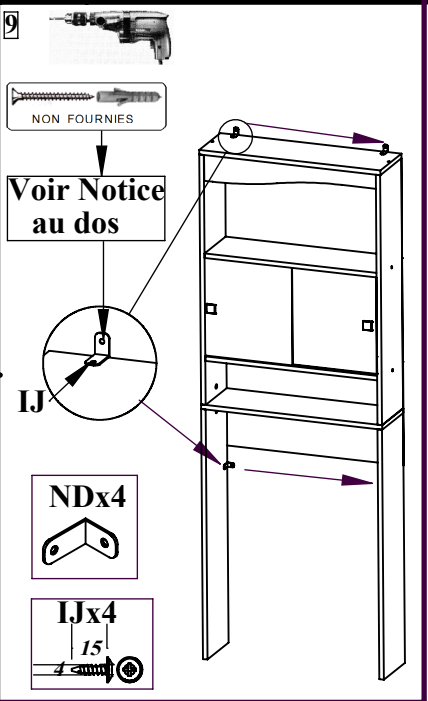
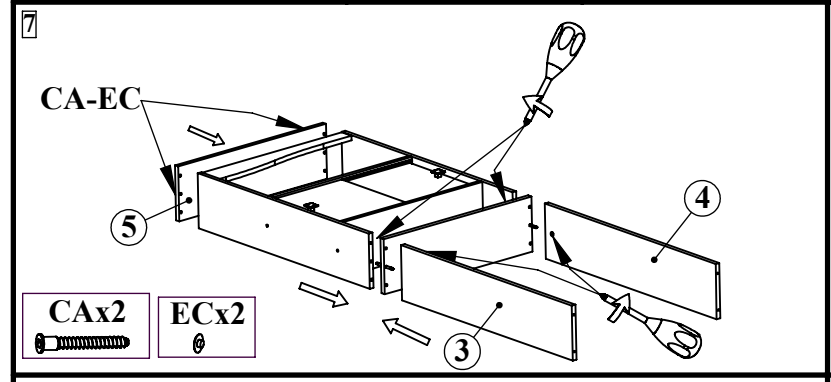
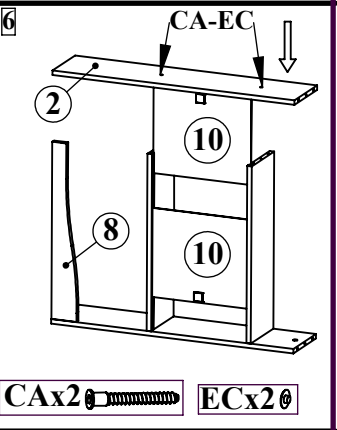
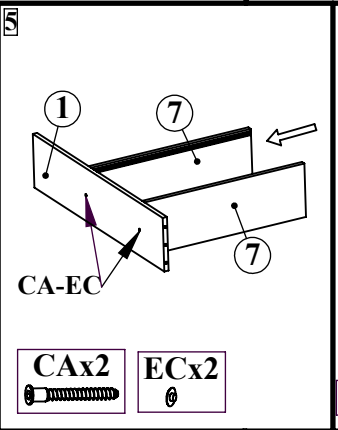
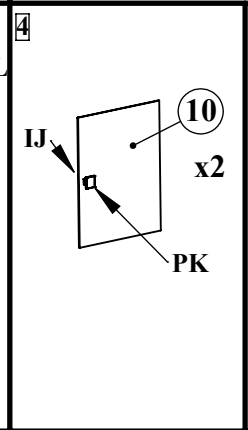
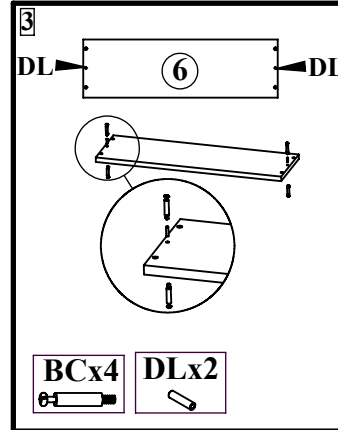
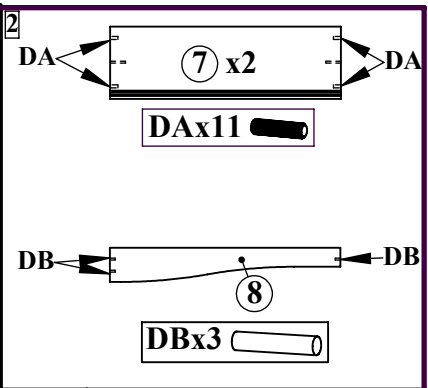
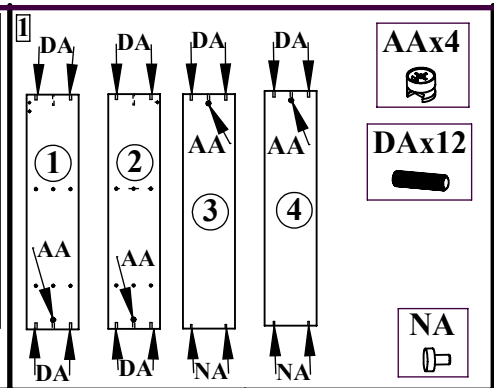

- Confira o conteúdo da sua encomenda antes de iniciar a montagem.  
 - Proceça a montagem do móvel seguindo a ordem definida pela numeração.  
 - Não danifique a embalagem, poderá ser-lhe útil para proteger os elementos de golpes ou riscos dur ante a montagem.  
 - Para qualquer esclarecimento, contacte os nossos serviços através do telefone.



Code	Long	Larg	Ep	Qté
1	869	192	16	1
2	869	192	16	1
3	869	192	16	1
4	869	192	16	1
5	643	192	16	1
6	643	192	16	1
7	610	191	16	2
8	610	90	16	1
9	640	360	3	3
10	351	307	3	2

! !

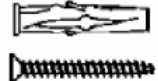
Il existe une grande diversité de types de murs ou cloisons, c'est la raison pour laquelle nous ne pouvons vous fournir le type exact de fixation. Il est nécessaire d'identifier le type de paroi à laquelle vous allez fixer ce produit afin de vous procurer les fixations appropriées. Voici quelques exemples de fixations conseillées pour :

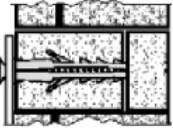
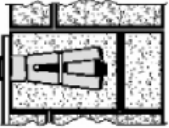
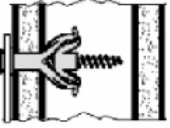
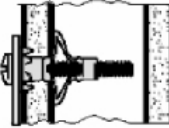
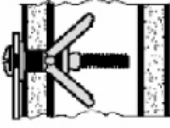







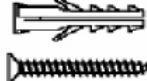

LES MURS PLEINS		LES CLOISONS CREUSES		
<b>CHEVILLE NYLON "FISCHER"</b> 	<b>CHEVILLE D'ANCRAGE MÉTAL</b> 	<b>CHEVILLE D'ANCRAGE À AILETTES EN NYLON</b> 	<b>CHEVILLE MÉTALLIQUE À EXPANSION</b> 	<b>CHEVILLE "MOLLY"</b> 
				

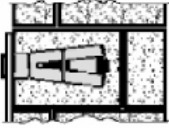

Utiliser une taille de forêt adaptée à la quincaillerie utilisée et au type de mur.

! !

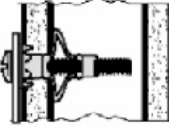
Due to the wide diversity of wall or partition types, we cannot provide you with suitable attachment fixtures. To determine which attachment fixtures to use, you will need to identify the type of wall to which you will be fixing this product. Here are some examples of attachment fixtures recommended for:







BLIND WALLS		STUDDED WALLS		
<b>"FISCHER" Nylon plug</b> 	<b>Metal Wall plug</b> 	<b>Nylon winged Wall plug</b> 	<b>Metal expansion plug</b> 	<b>"MOLLY" plug</b> 
				

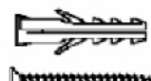

Use a drill bit that is compatible in size with the hardware used and the type of wall.

! !

Esiste una gran varietà di tipi di muri o paratie e noi siamo in grado di fornirvi il tipo esatto di fissaggio per ognuno di essi. È necessario identificare il tipo di parete alla quale intendete fissare questo prodotto in modo da fornirvi i fissaggi più idonei. Ecco qualche esempio di fissaggi consigliati per :

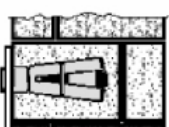
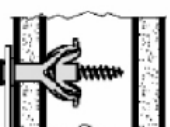
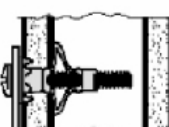
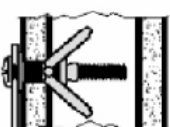







I MURI PIENI		PARATIE CAVE		
<b>TASSELLO NYLON "FISCHER"</b> 	<b>TASSELLO DI ANCORAGGIO IN METALLO</b> 	<b>TASSELLO DI ANCORAGGIO AD ALETTE IN NYLON</b> 	<b>TASSELLO METALLICO AD ESPANSIONE</b> 	<b>TASSELLO "MOLLY"</b> 
				



Utilizzare una punta di trapano adatta agli utensili utilizzati e al tipo di muro.

! !

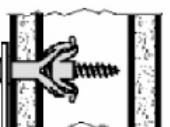
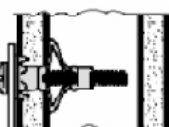
Es gibt eine Vielzahl verschiedener Arten von Mauern oder Zwischenwänden, und aus diesem Grunde können wir Ihnen den genau entsprechenden Befestigungstyp nicht bereitstellen. Zunächst ist es erforderlich, die exakte Bauart der Wand zu ermitteln, an der Sie dieses Produkt anbringen werden, um die für diese Wand geeigneten Befestigungsmittel im Fachhandel erwerben zu können. Nachfolgend einige Beispiele empfohlener Befestigungen für:

VOLLWÄNDE		HOHLWÄNDE		
<b>NYLONDÜBEL "FISCHER"</b> 	<b>ANKERDÜBEL AUS METALL</b> 	<b>ANKERDÜBEL MIT NYLONFLÜGELN</b> 	<b>HOHLWÄNDE SPREIZDÜBEL FÜR VERANKERUNG AUS METALL</b> 	<b>MOLLY-DÜBEL</b> 
				



Bitte verwenden Sie eine für die Eisenwaren und den Wandtyp geeignete Bohrergöße.