

FR Description du produit
EN Product description
ES Descripción del producto
DE Produktbeschreibung

NEO

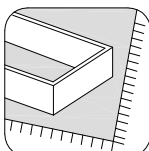
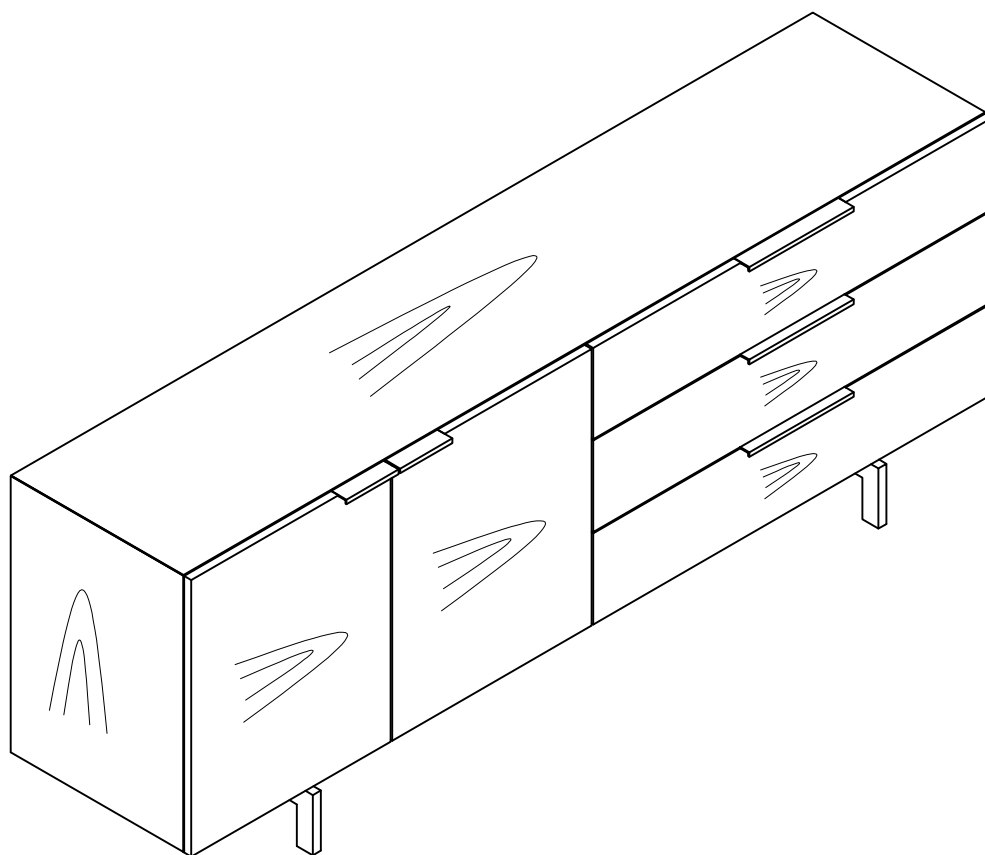

Meuble à usage domestique / Domestic furniture / Meuble a uso domestico / Möbel für den häuslichen Wohngebrauch

154586NOYE WALNUT / URS / NUSSBAUM / OSCURO

'3517920697960 WALNUT / URS / NUSSBAUM / OSCURO

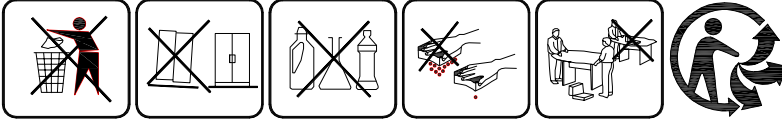

1. Reperez les pieces constituant votre meuble.
2. Regroupez et comptez la quincaillerie.
3. Munissez vous de l'outillage necessaire.
4. Amenez vous une zone de montage, la moquette ou une couverture protegera des rayures.
5. procedez au montage, ne jamais forcer sur les assemblages, resserez les vis apres quelques temps d'usage.



FR

Gardez votre notice de montage.

Si une piece venait a manquer elle sera le moyen le plus clair pour communiquer avec votre magasin.
Nous conseillons d'aérer la pièce lors du montage et quelques heures après

1. Identify the parts which make up your piece of furniture.
2. Gather the hardware parts and count them.
3. Have the necessary tools ready.
4. Organize a space for assembly, wall carpeting or a blanket will protect the furniture against scratches.
5. Mount the furniture, never force the parts to be assembled.



EN

Tighten the screws after it has been used for some time.

Keep the assembly instruction since it will help you when you get in touch with the store if a part should be missing.
We advise ventilating the room during installation and during few hours after.

1. Localice las piezas que componen su mueble.
2. Reagrupe y cuente la tornilleria.
3. Prepare las herramientas necesarias.
4. Prepare una zona de montaje, la moqueta o una manta protegerá de arañazos.
5. Proceda al montaje, no forzar sobre los embalages, apretar los tornillos después de algún tiempo de uso.



ES

Guardar las instrucciones de montaje.

Si una pieza le faltase, sera la manera mas facil de comunicarse con su proveedor.
Aconsejamos ventilar la zona durante la instalación y algunas horas después.

1. Bitte überprüfen Sie, ob alle Einzelteile Ihres Möbelstücks vorhanden sind.
2. Bitte überprüfen Sie, ob alle Schrauben und Verbindungsteile für die Montage vorhanden sind.
3. Halten sie alle notwendigen Montage-Werkzeuge für ihren Einsatz gebrauchsbereit.
4. Bereiten Sie einen passenden Ort für die Montage vor. Ein Teppichboden oder ähnliches schützt vor Kratzern.
5. Beginnen Sie mit der Montage. Lassen Sie sich Zeit und fügen Sie die Einzelteile nie mit Gewalt zusammen.



DE

Um einen langfristigen und einwandfreien Gebrauch zu gewährleisten, ziehen Sie die einzelnen Schrauben regelmäßig nach längerer Nutzung des Möbelstücks fest.

Bitte bewahren Sie diese Montageanleitung auf. Diese gewährleistet im Problemfall einen reibungslosen und schnellen Kommunikationsaustausch mit dem Kundenservice Ihres Geschäfts.

Wir beraten, lüften Sie den Raum während der Installation und ein paar Stunden später.

IMPORTANT, A CONSERVEZ-LES POUR UNE
REFERENCE ULTERIEURE: LIRE
ATTENTIVEMENT

IMPORTANT, RETAIN FOR FUTURE REFERENCE:
READ CAREFULLY

IMPORTANTE, CONSERVAR PARA FUTURAS
CONSULTAS: LEER ATENTAMENTE

WICHTIG, FÜR SPÄTERES NACHSCHLAGEN
AUFBEWAHREN: SORGFÄLTIG LESEN

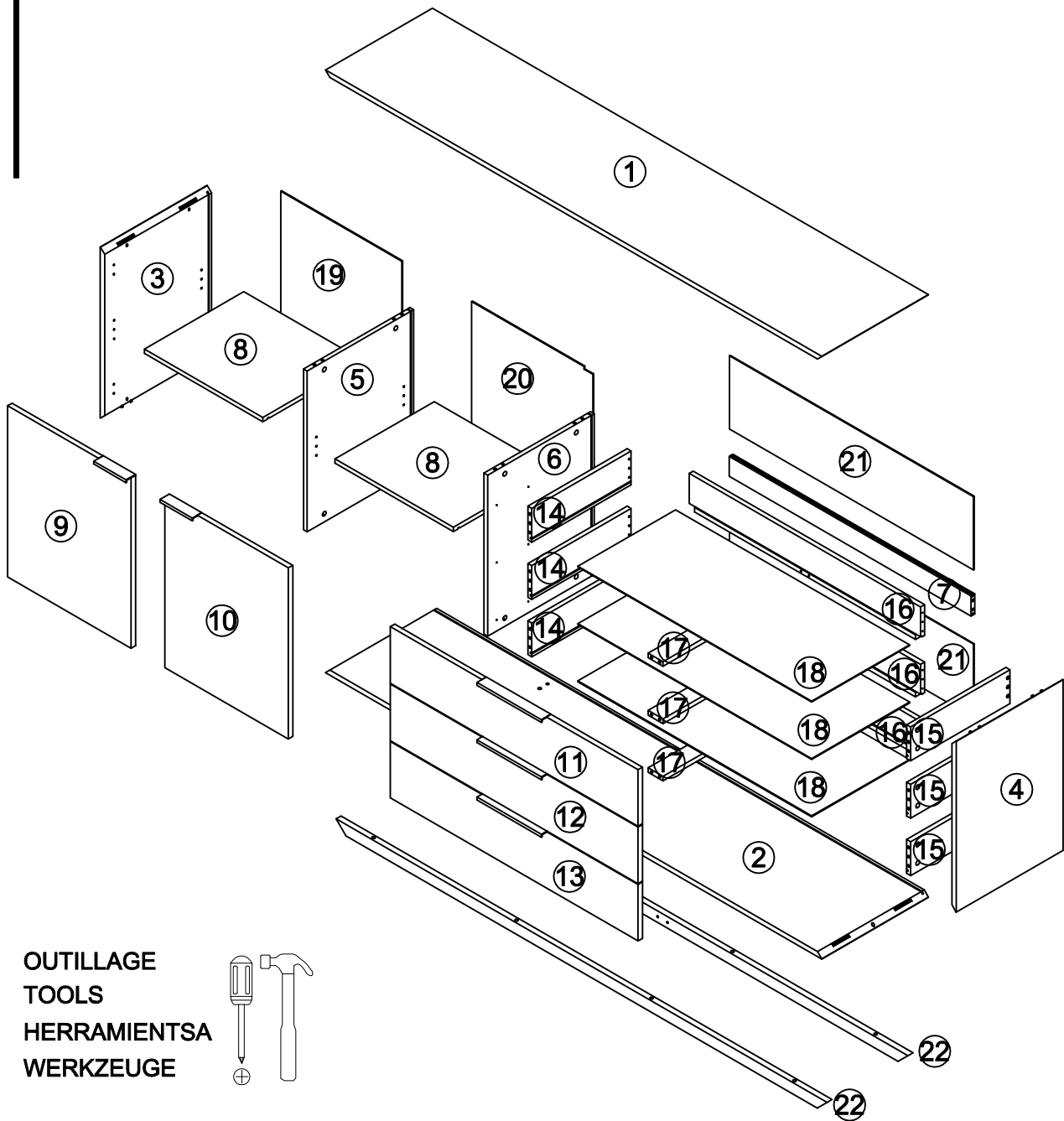



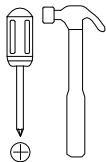





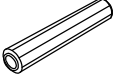

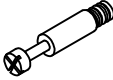

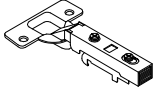
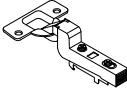
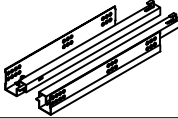







OUTILLAGE
 TOOLS
 HERRAMIENTSA
 WERKZEUGE

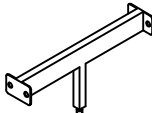
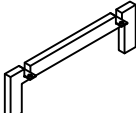

No.	Taille	Qté	Ctn no.
No.	Size	Qty	Ctn no.
No.	Tamaño	Cant	Ctn no.
Nr.	Maße	Anzahl	Ktn nr.
1	1997x429x18	1	3/3
2	1997x429x18	1	3/3
3	595x429x18	1	1/3
4	595x429x18	1	1/3
5	561x429x15	1	1/3
6	561x429x15	1	1/3
7	974x70x15	1	2/3
8	477x400x15	2	1/3
9	596x496x18	1	2/3
10	596x496x18	1	2/3
11	997x196x18	1	2/3

No.	Taille	Qté	Ctn no.
No.	Size	Qty	Ctn no.
No.	Tamaño	Cant	Ctn no.
Nr.	Maße	Anzahl	Ktn nr.
12	997x196x18	1	2/3
13	997x196x18	1	2/3
14	400x118x16	3	1/3
15	400x118x16	3	1/3
16	932x124x16	3	2/3
17	384x60x16	3	1/3
18	942x394x3	3	2/3
19	572x488x3	1	1/3
20	572x488x3	1	1/3
21	983x256x3	2	3/3
22	1978x40x20	2	3/3

101	X14	102	X30	103	X30	104	X4
							
8x35		15x12		8x35			
105	X2	106	X2	107	X3	108	X1
							
				400MM		M4	
109	X8	110	X2	111	X12	112	X8
							
		M6.5x47		M6x15		M6x50	
113	X8	114	X4	115	X8	116	X18
							
		20x1		3x18		4x14	
117	X15	118	X24	119	X1	120	X2
							
4x15		3.5x35		306x145x60		446x130x60	
121	X1	122	X1	123	X1		
							
20x215		6x30		4x30			

1

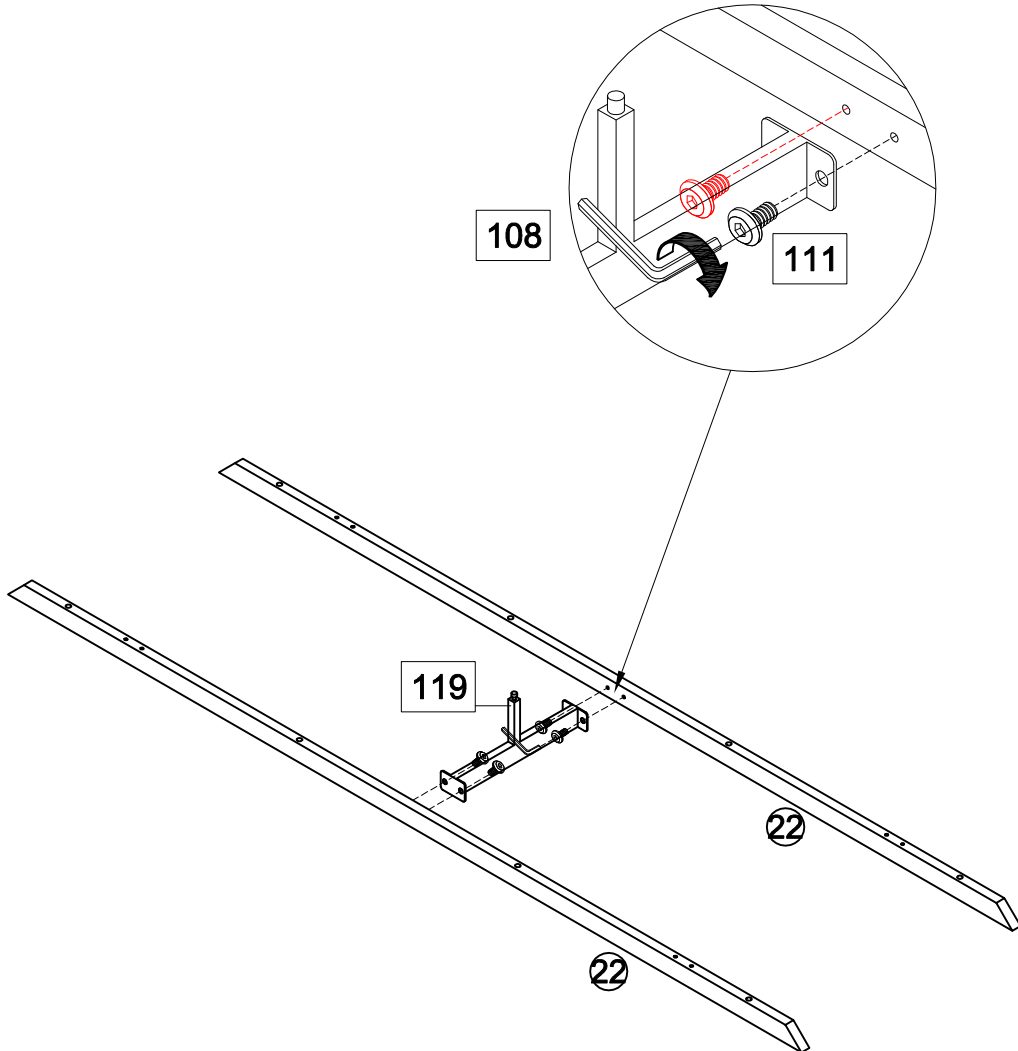



108	X1
M4	

111	X4
M6x15	

119	X1
306x145x60	

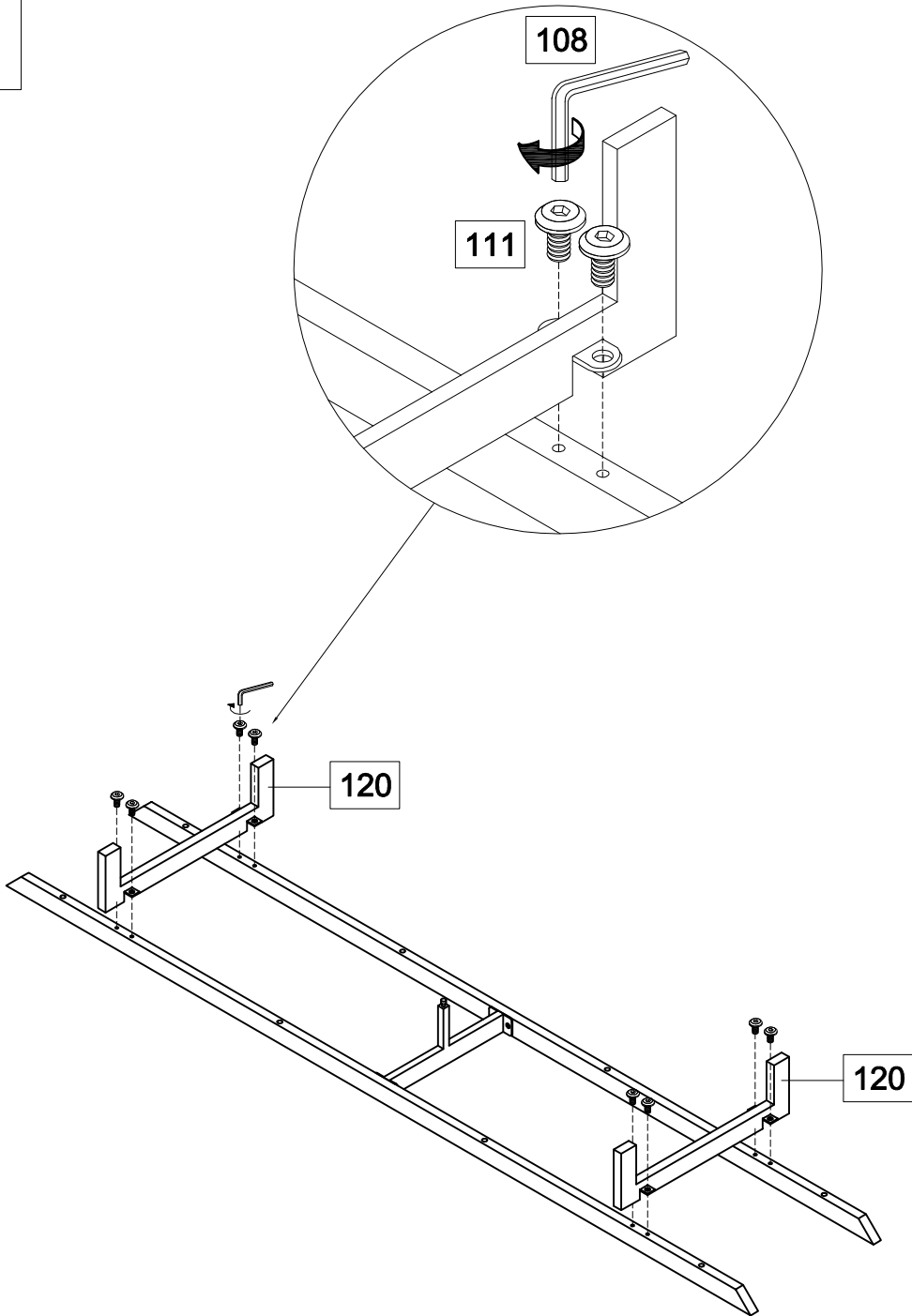
2



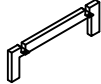

108	X1
	
M4	

111	X8
	
M6x15	

120	X2
	
446x130x60	

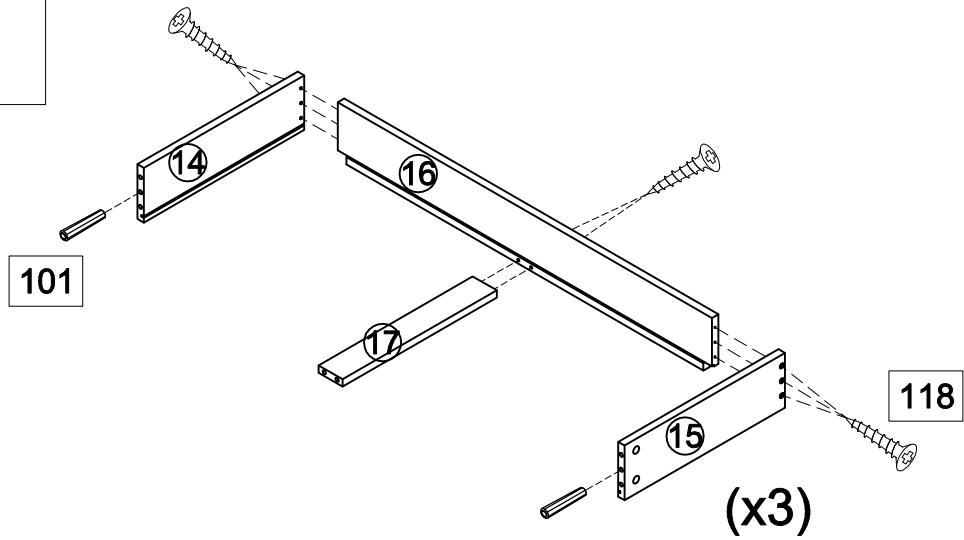
3



101	X6	118	X24
			
8x35		3.5x35	

4

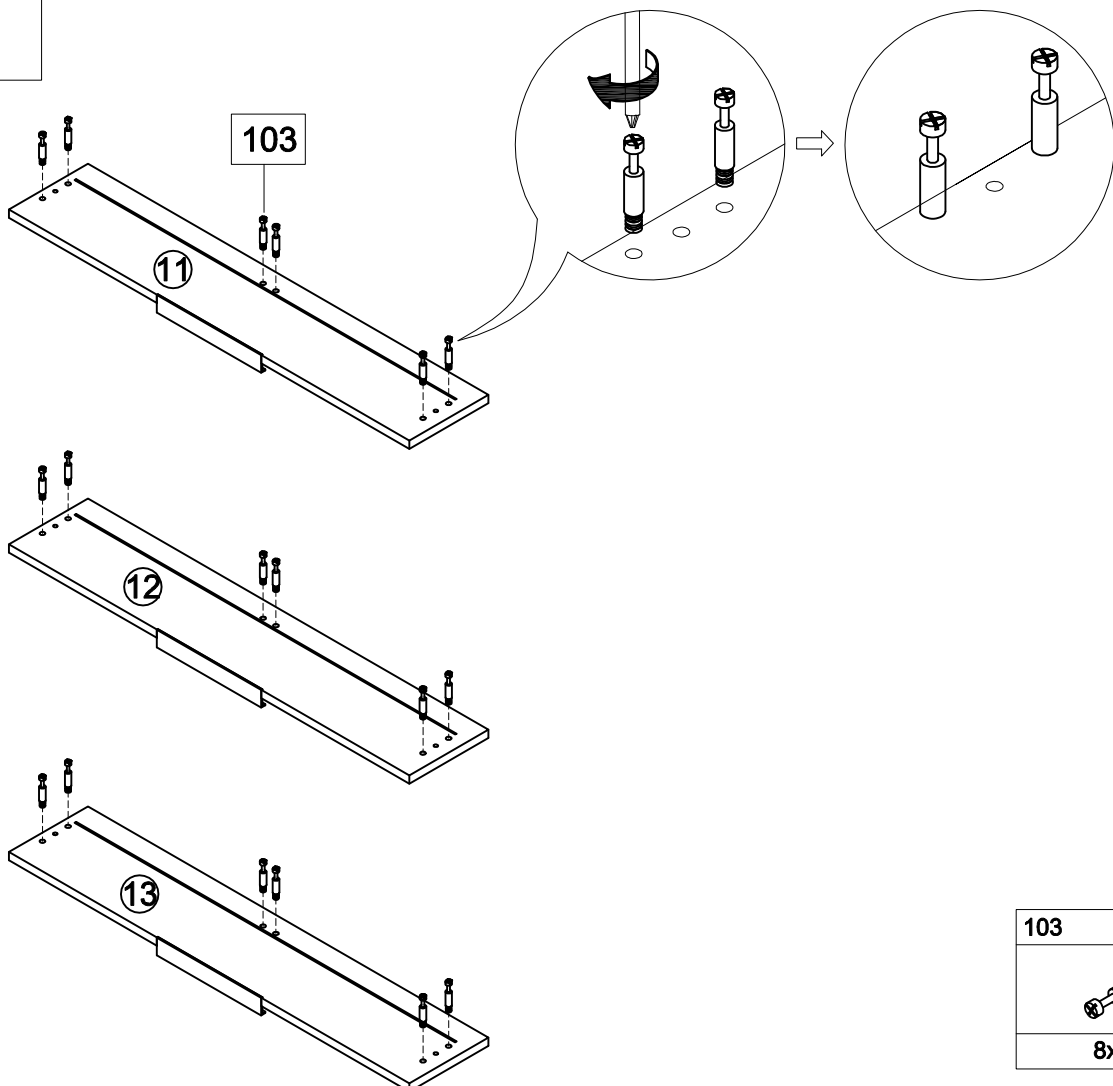

103	X18
	
8x35	

5

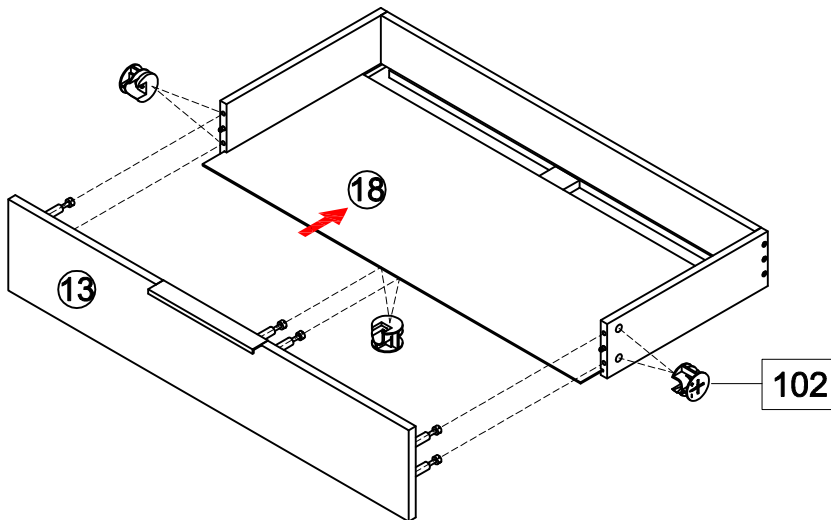
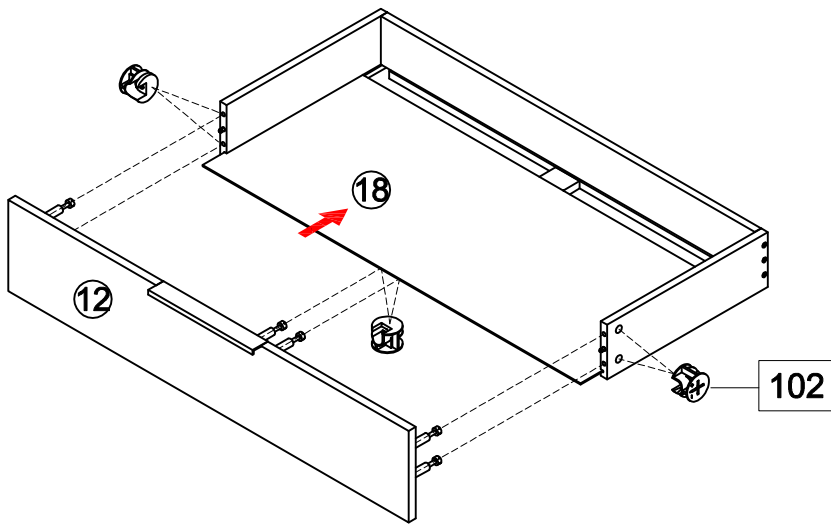
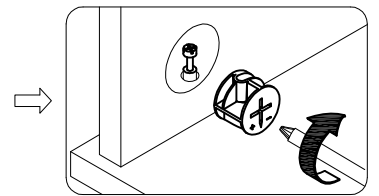
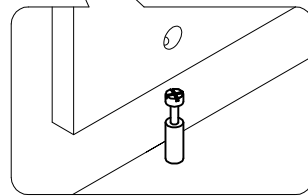
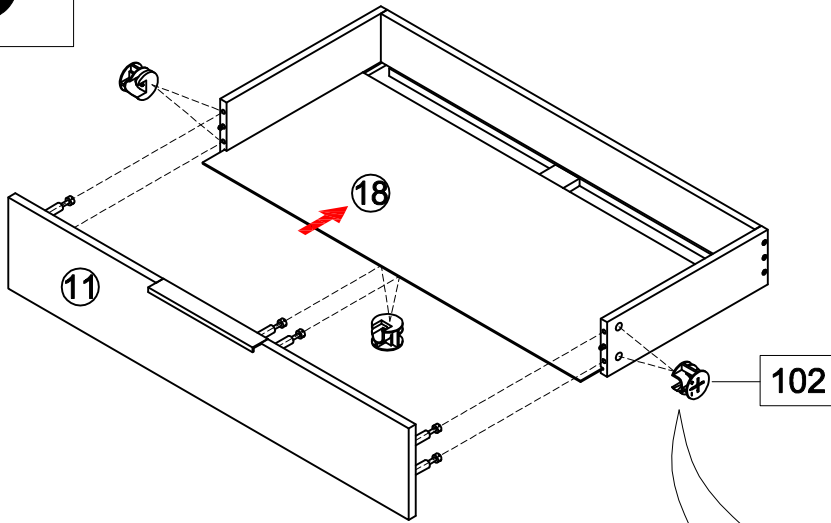

102	X18
15x12	

6

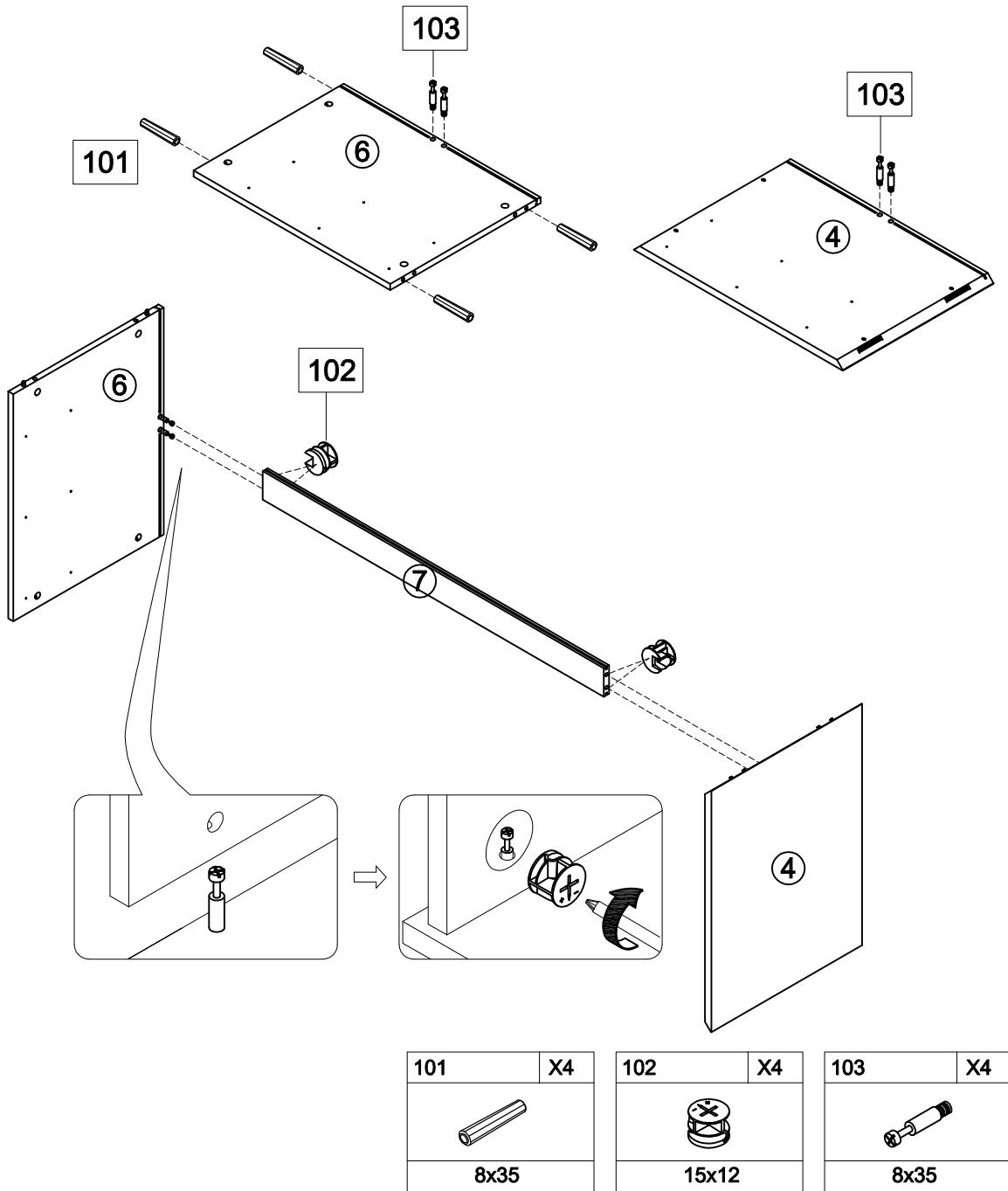



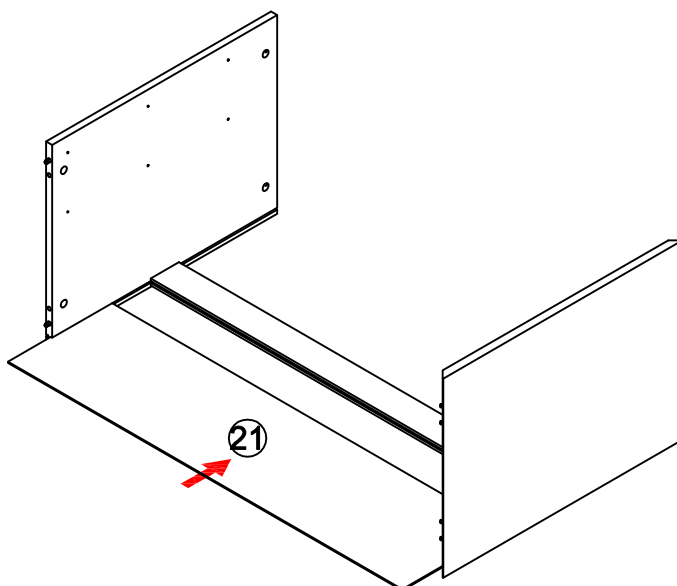

7

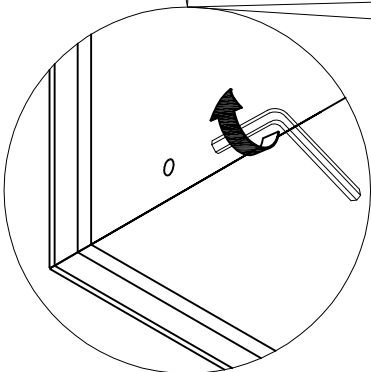
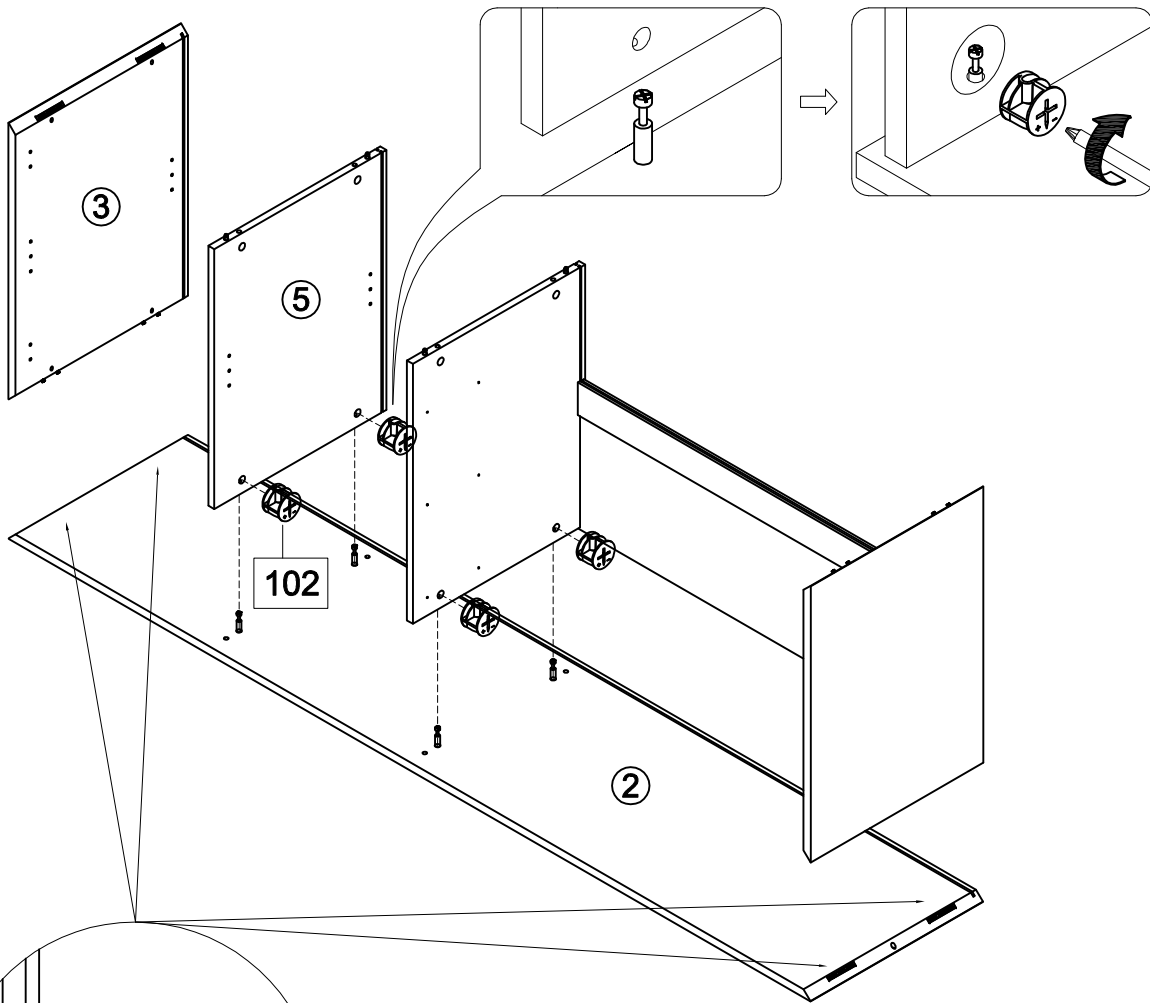
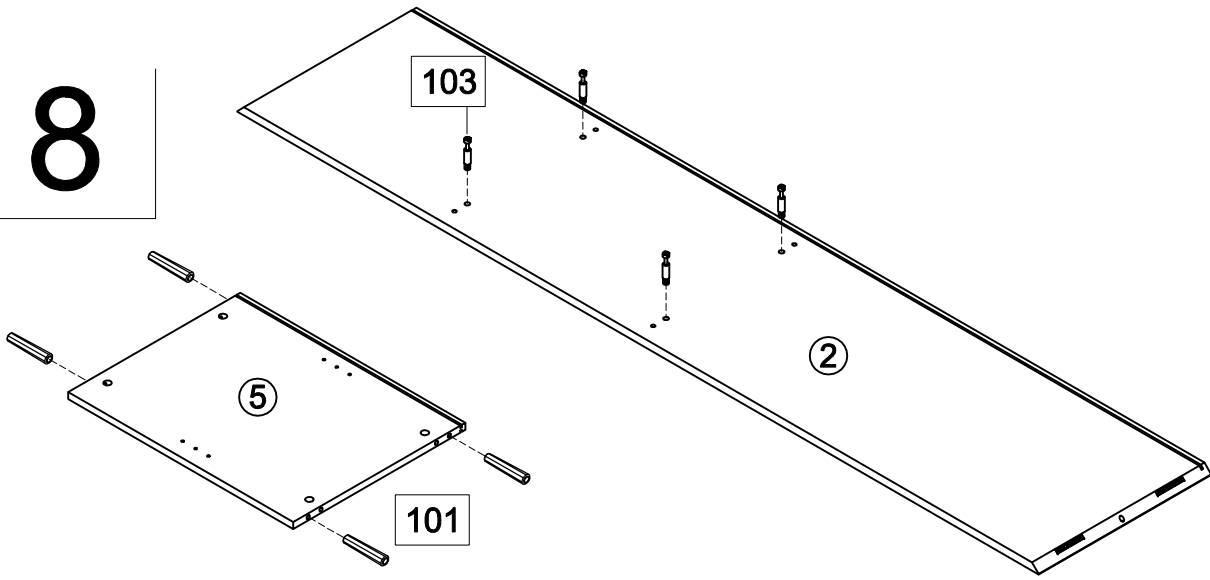

8



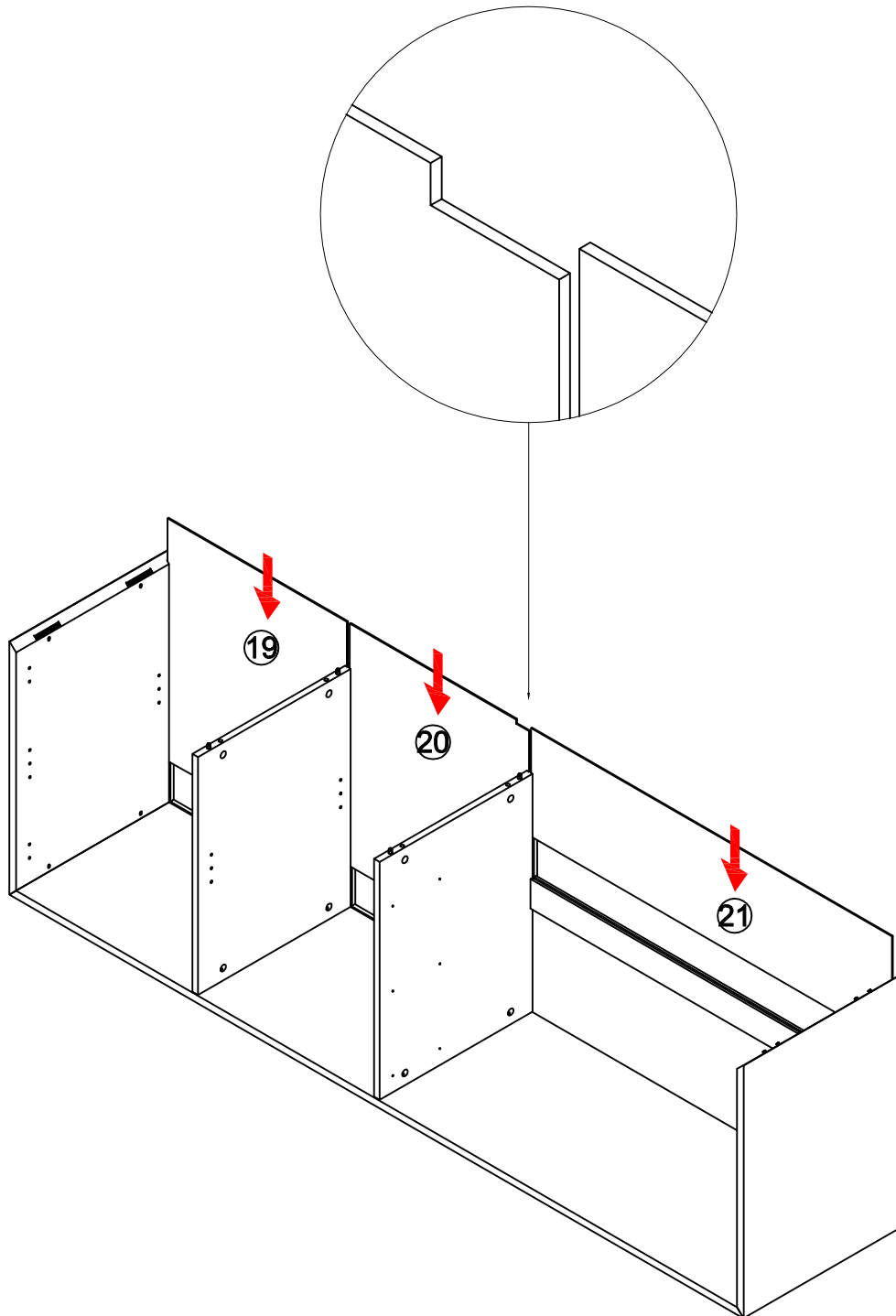

101	X4	102	X4
			
8x35		15x12	
103	X4	108	X1
			
8x35		M4	

9

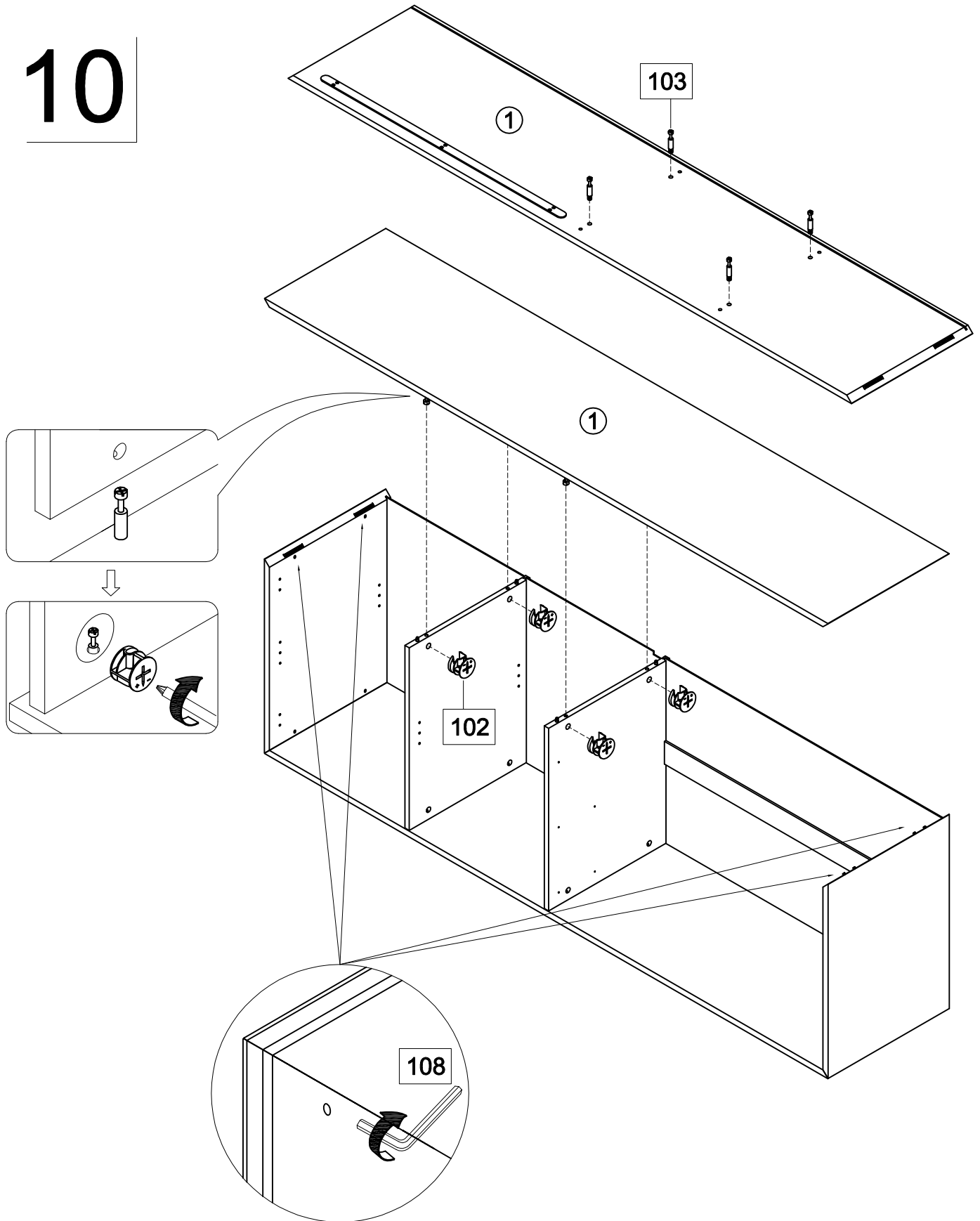

10





102	X4
	
15x12	

103	X4
	
8x35	

108	X1
	
M4	

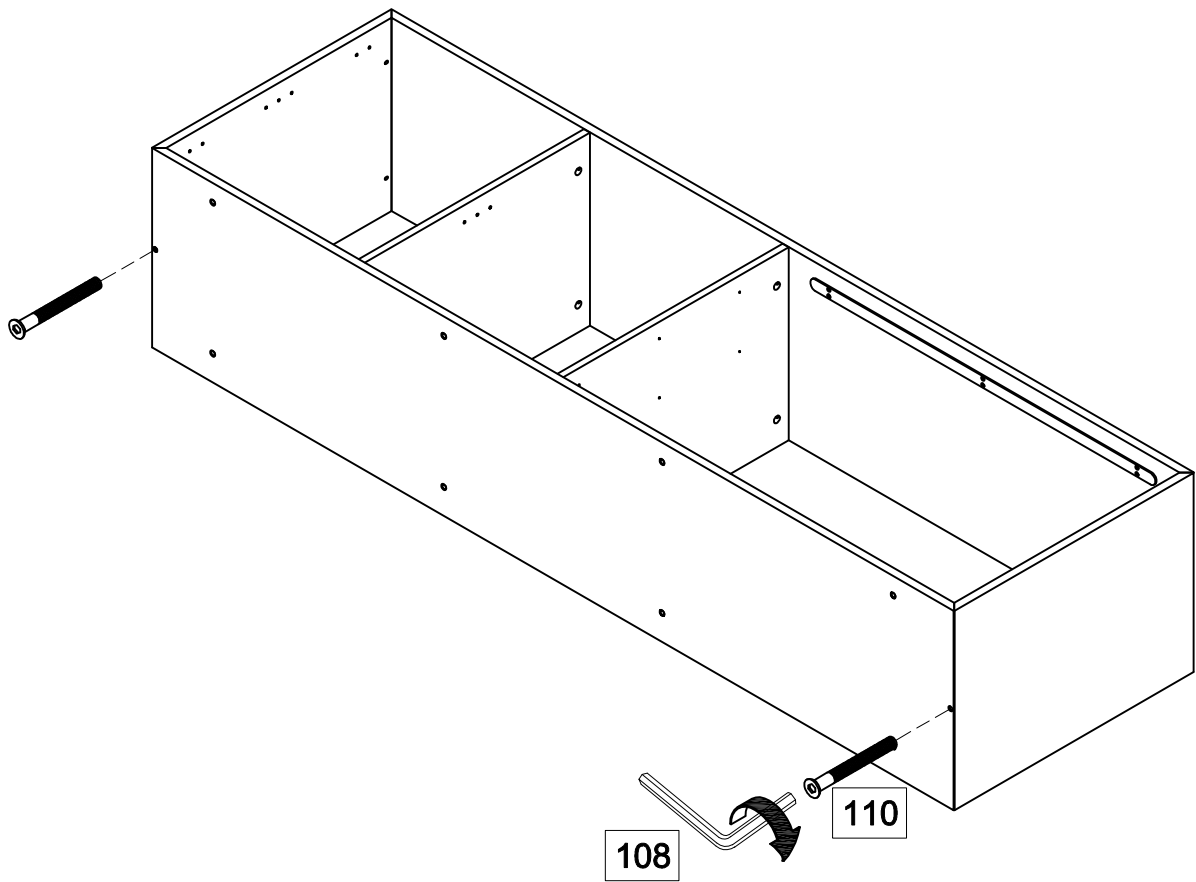
11



108	X1	110	X2
			
M4		M6.5x47	

12

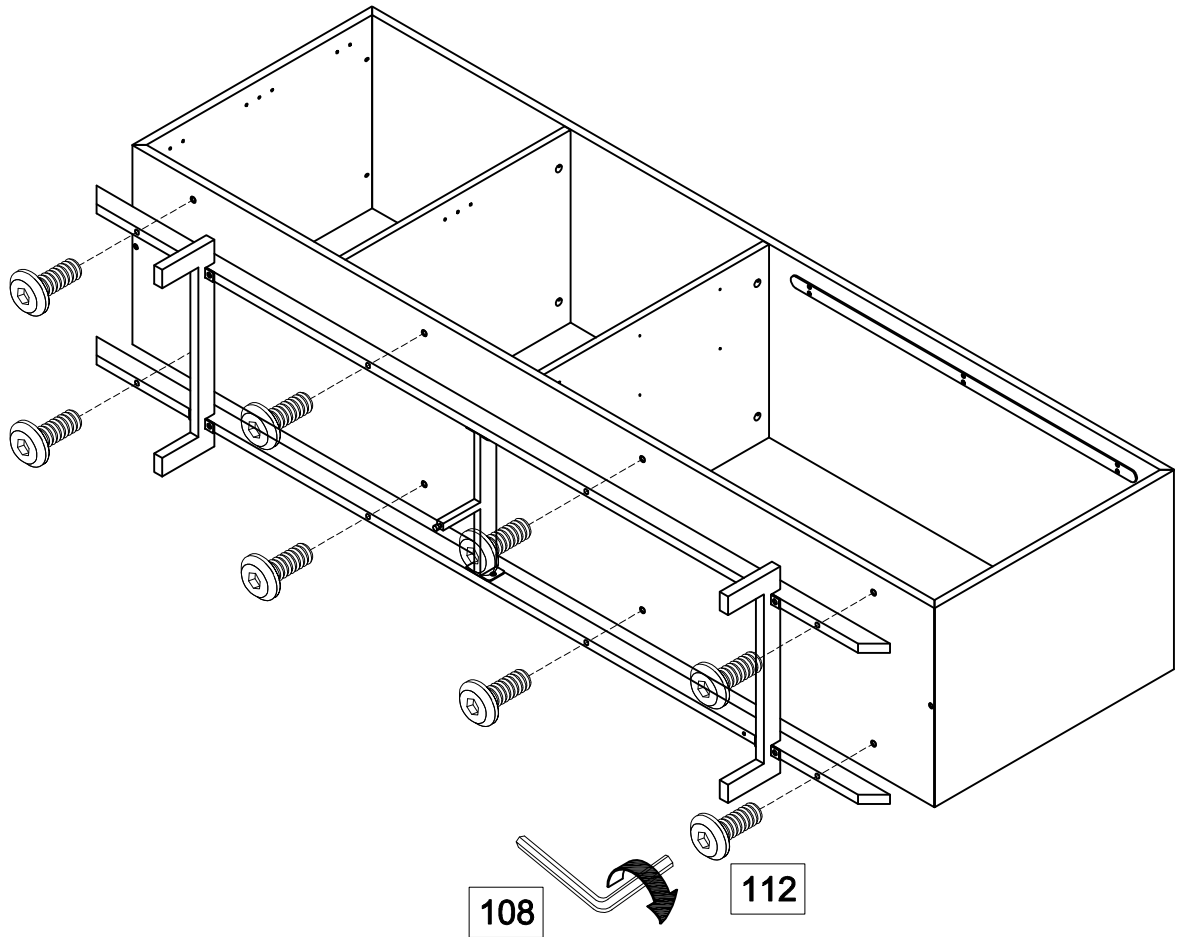

108	X1
	
M4	

112	X8
	
M6x50	

13

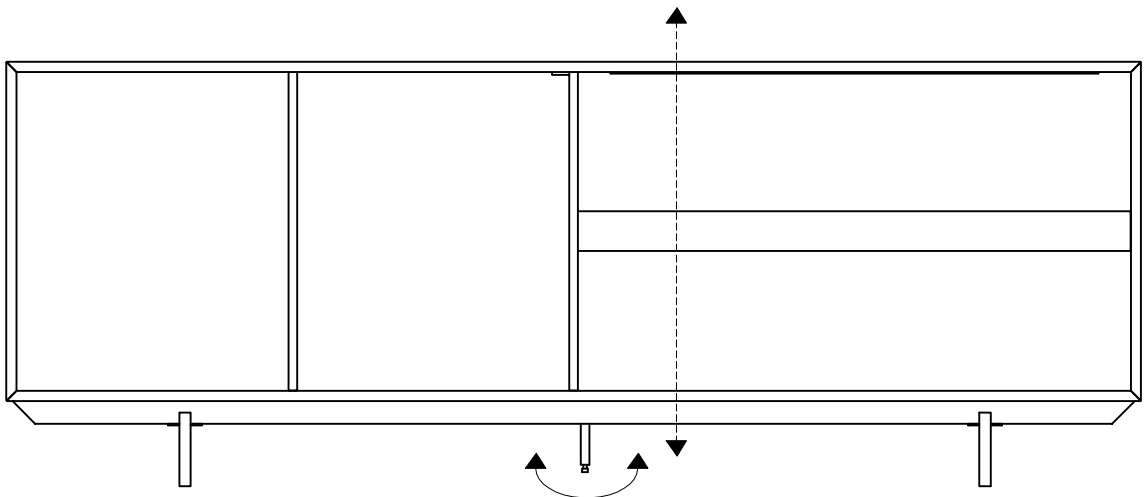
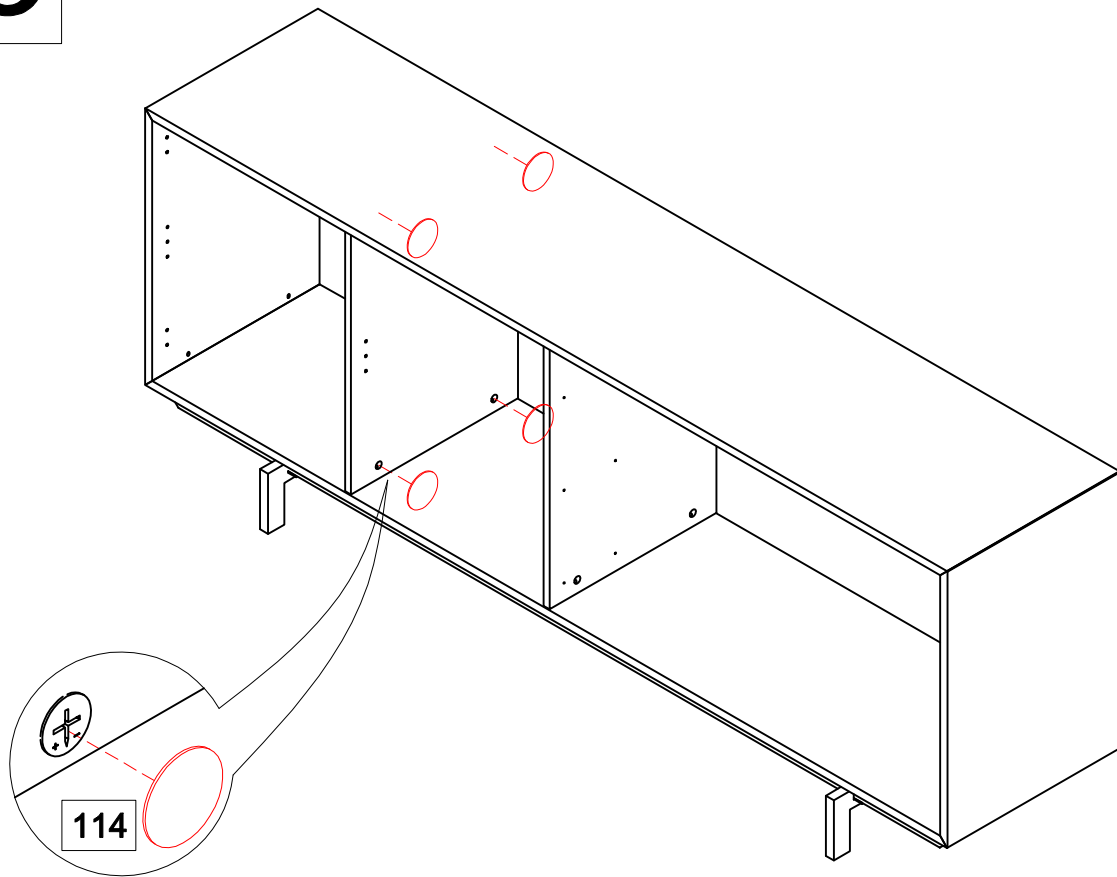

114	X4
	
20x1	

14

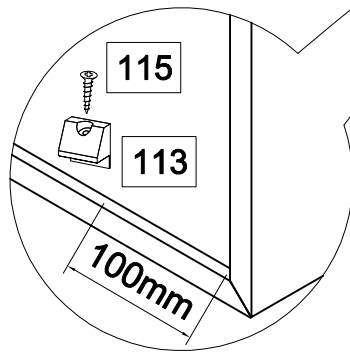
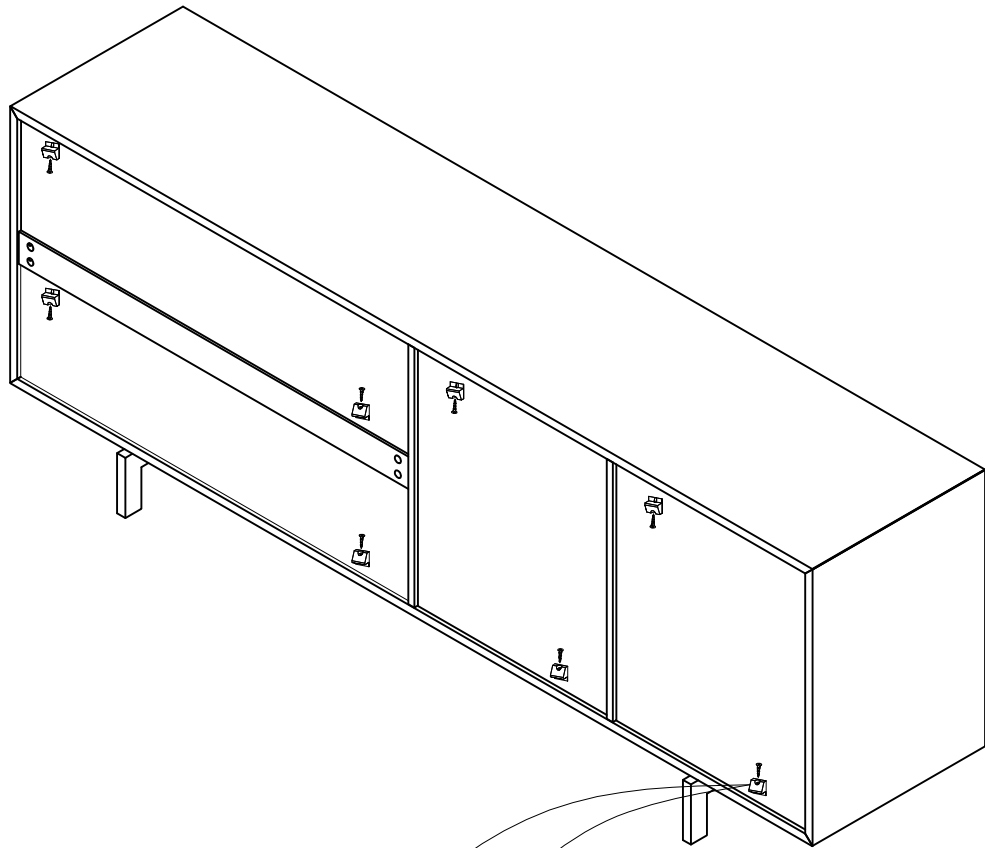



113	X8

115	X8
3x18	

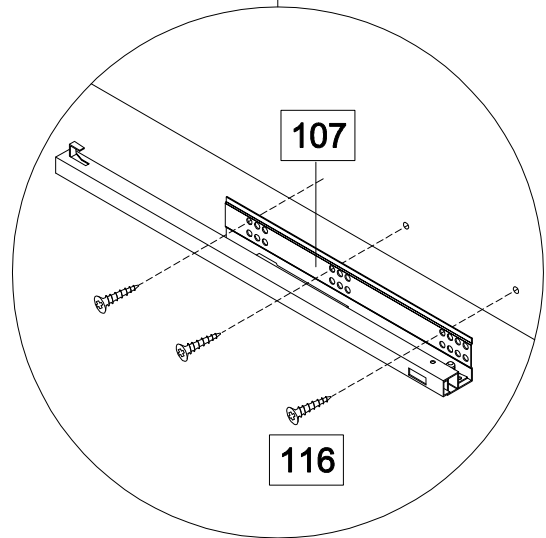
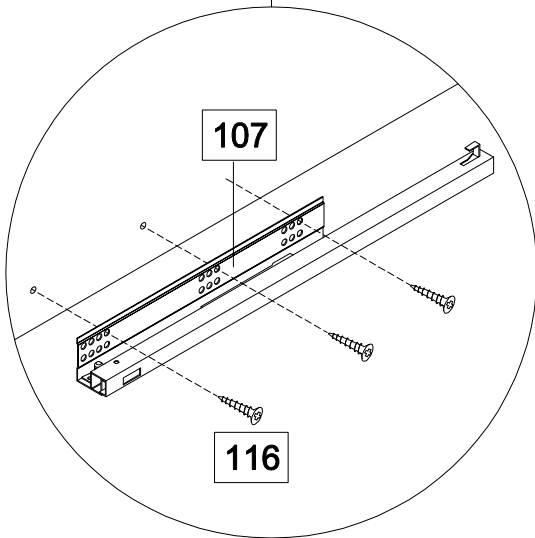
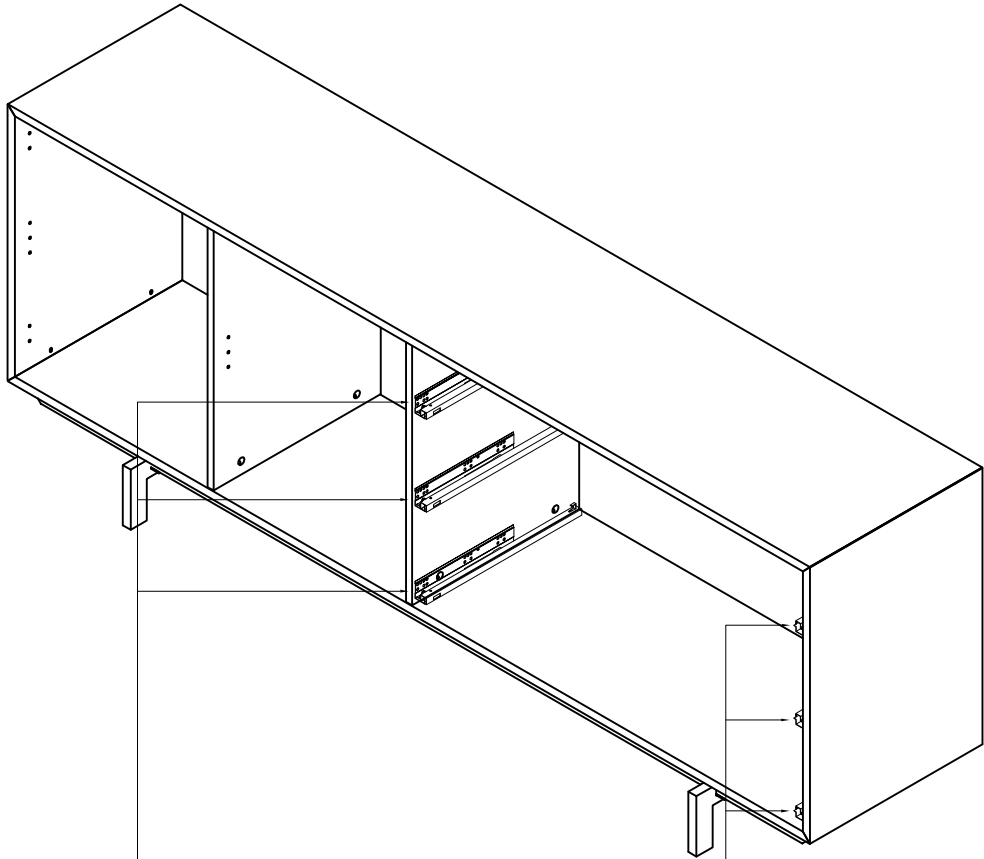
15

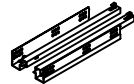

107	X3	116	X18
			
400MM		4x14	

16

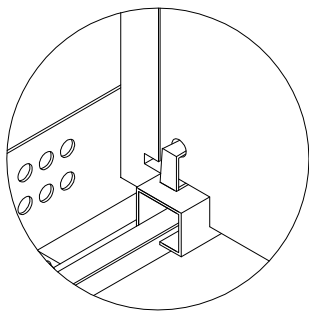
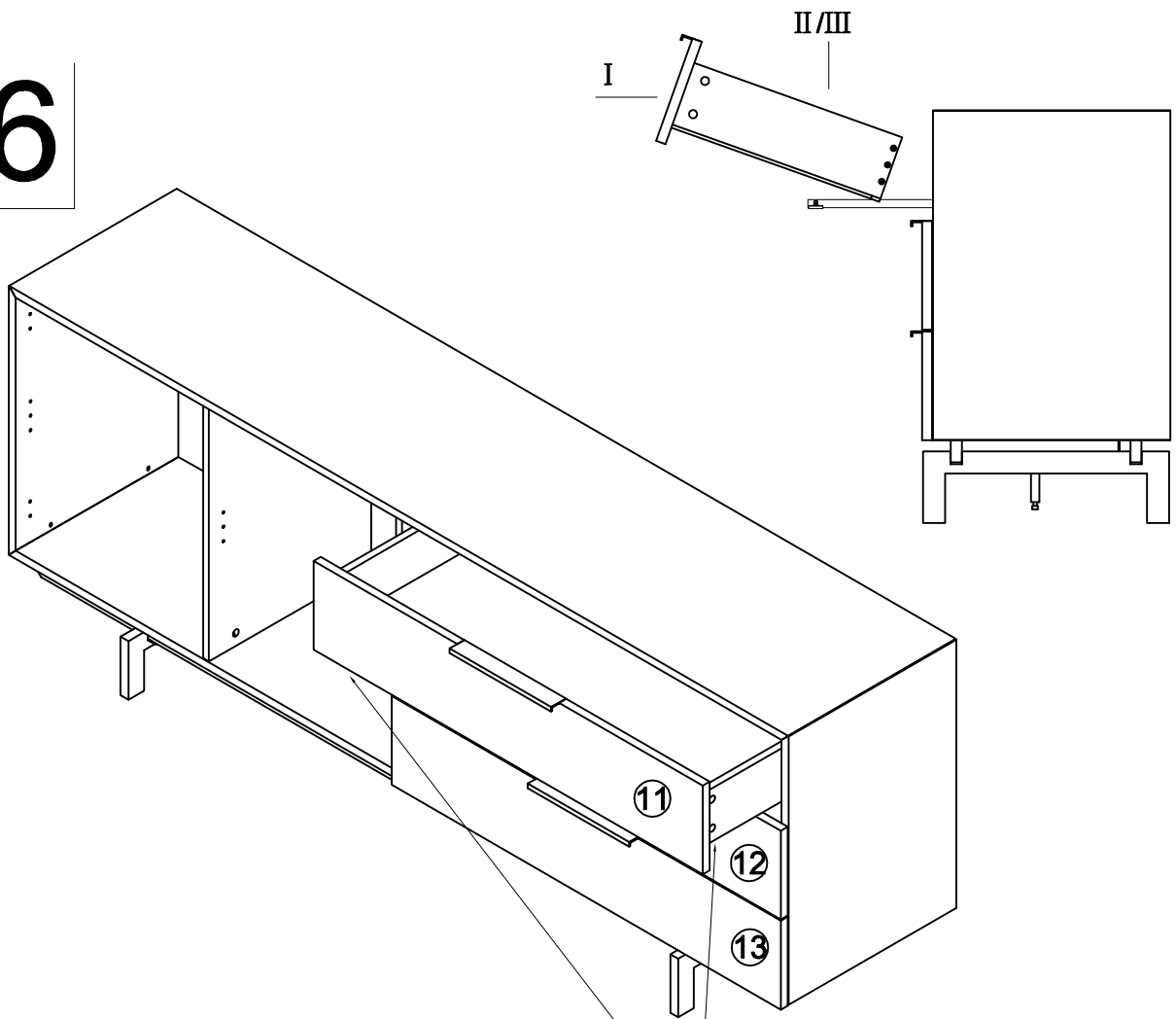

I

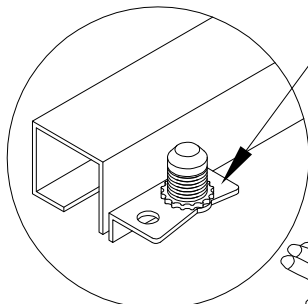

II

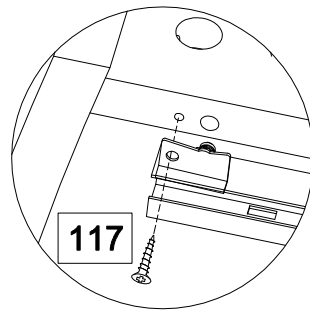

III

117	X6
	
4x15	

17

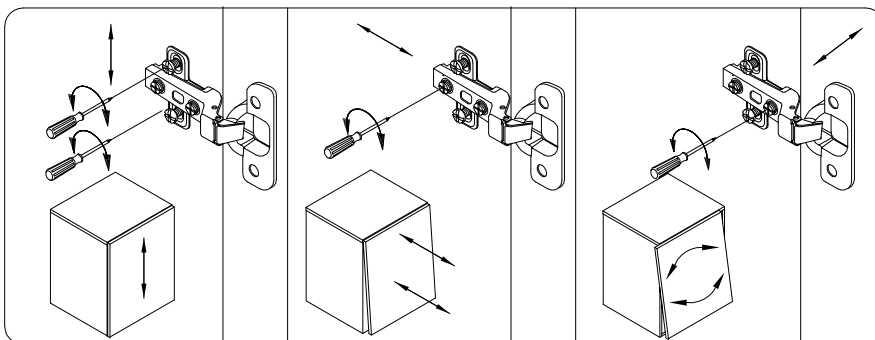
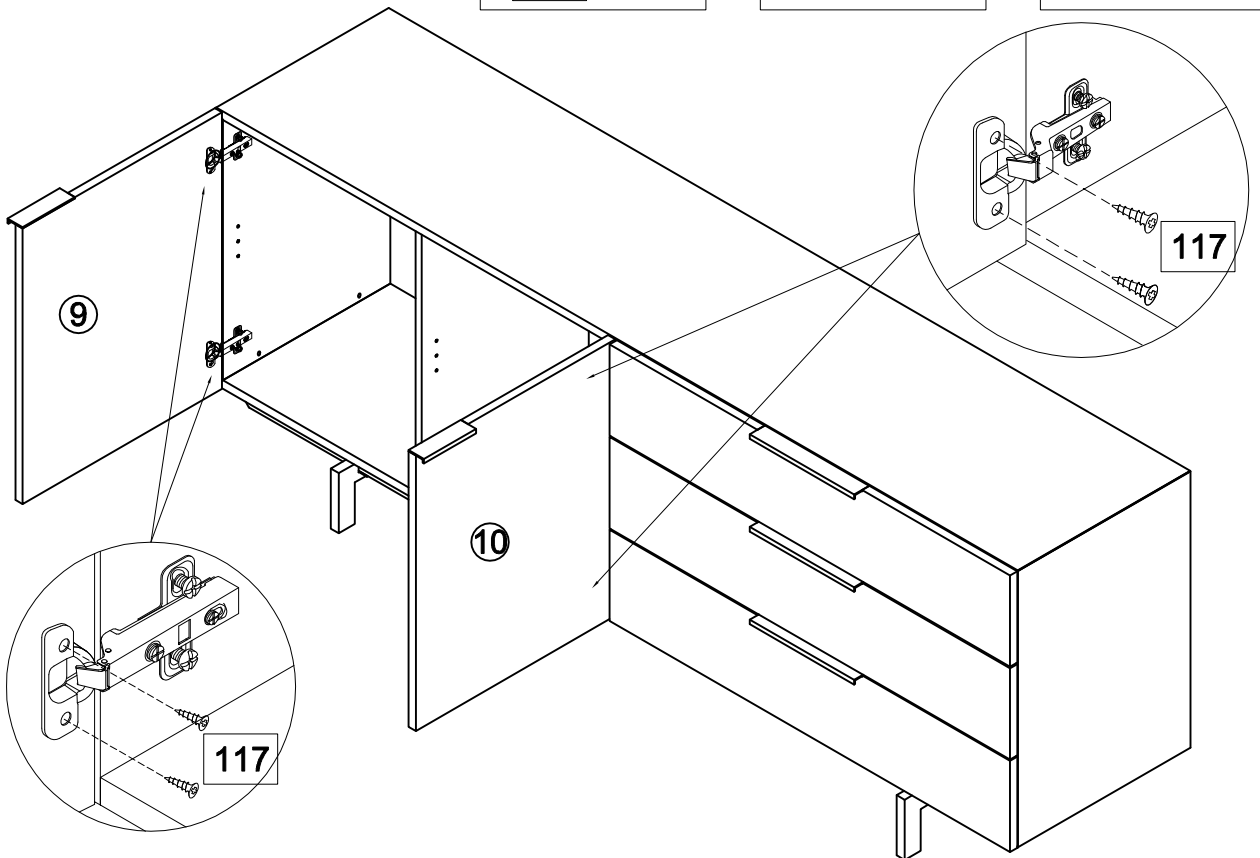
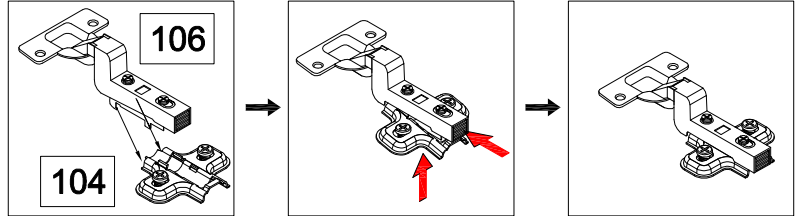
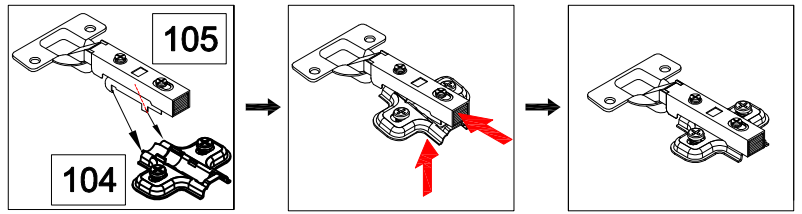

104	X4
	

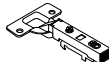
105	X2
	

106	X2
	

117	X8
	
4x15	

18

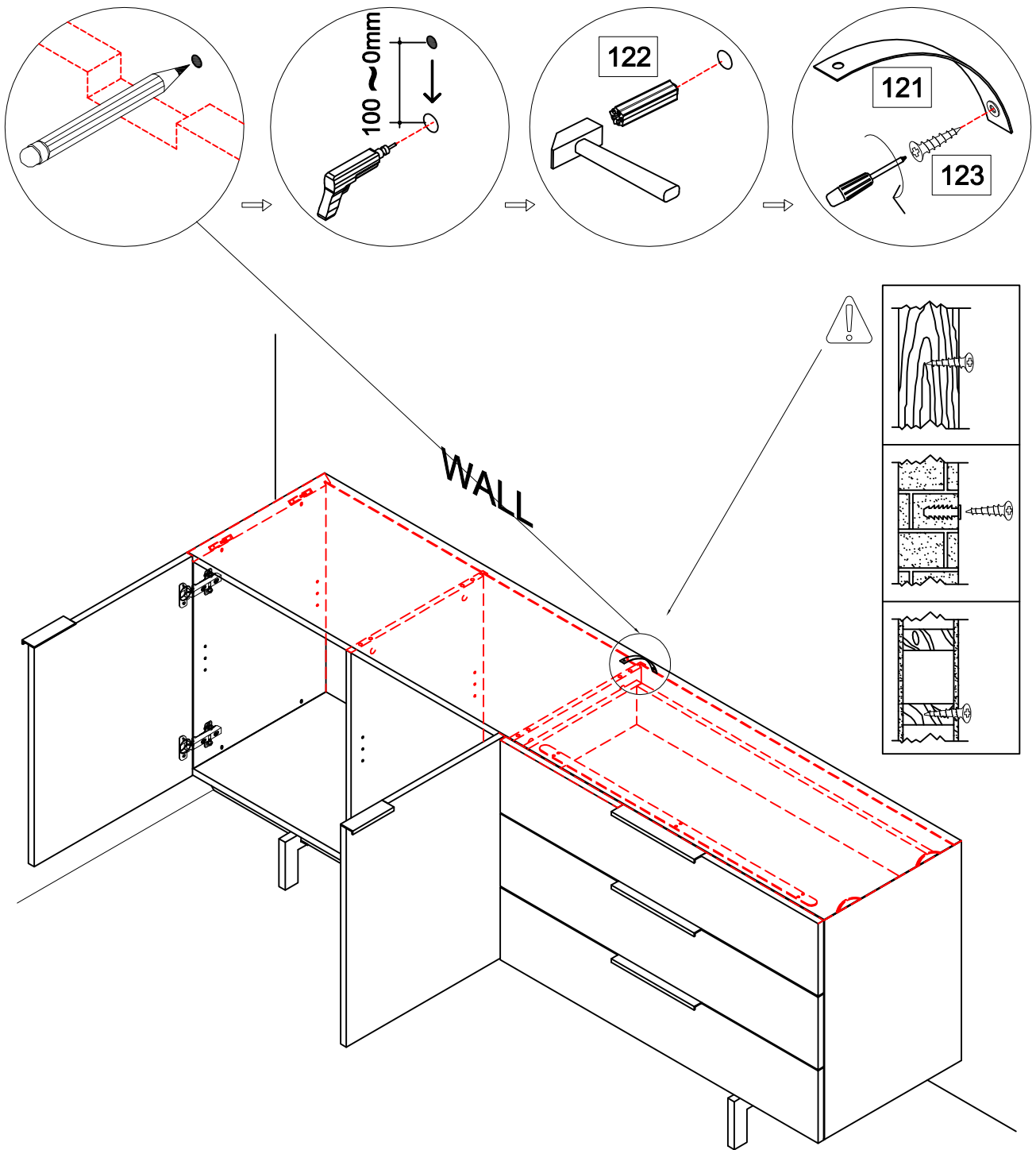



123	X1
4x30	

122	X1
6x30	

121	X1
20x215	

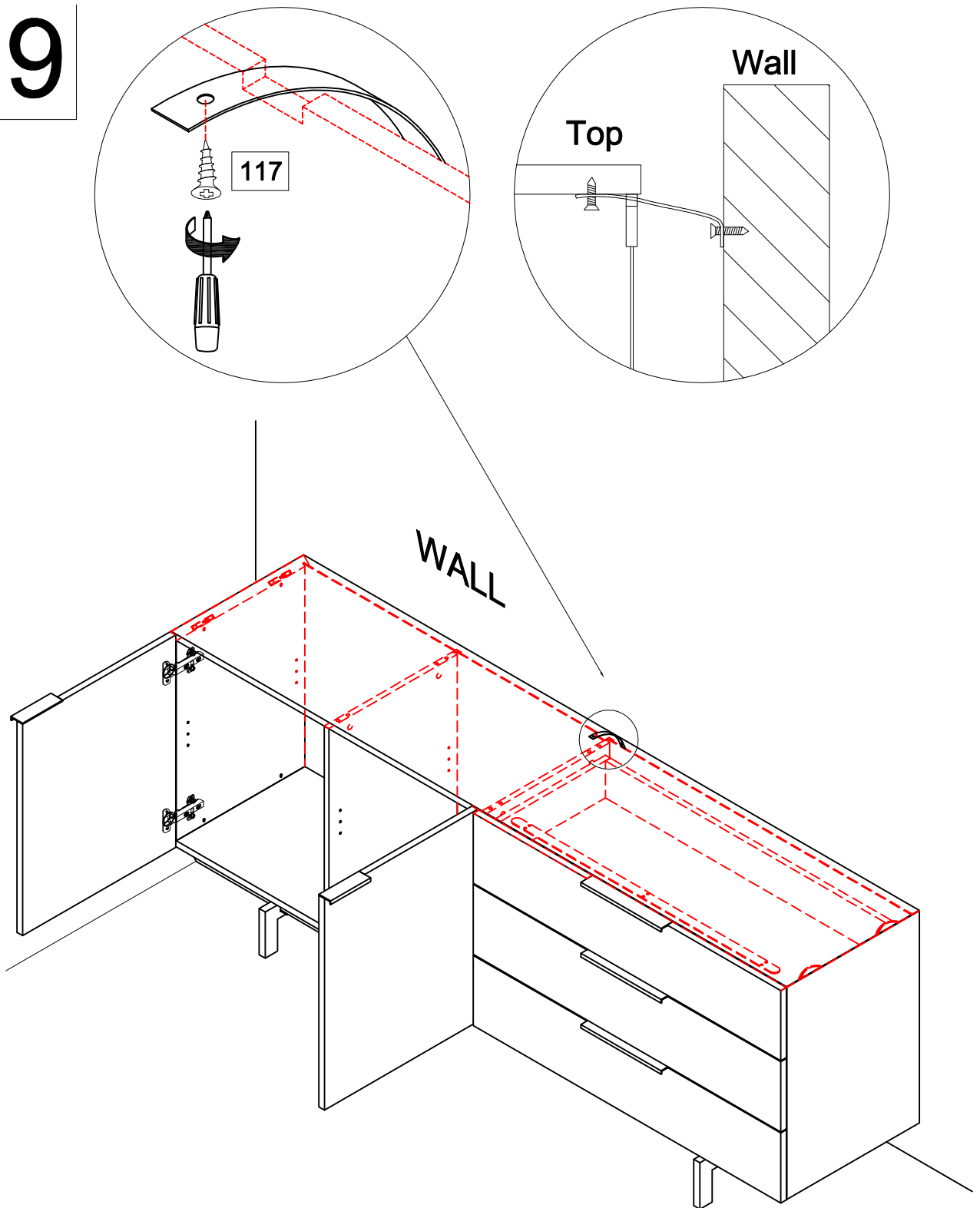
19



117	X1
	
4x15	

20

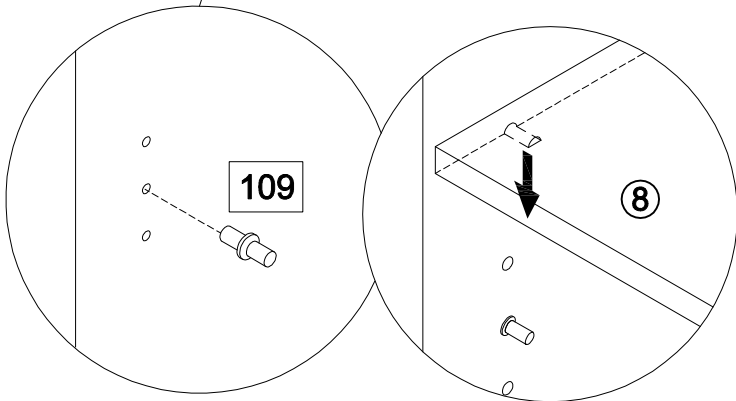
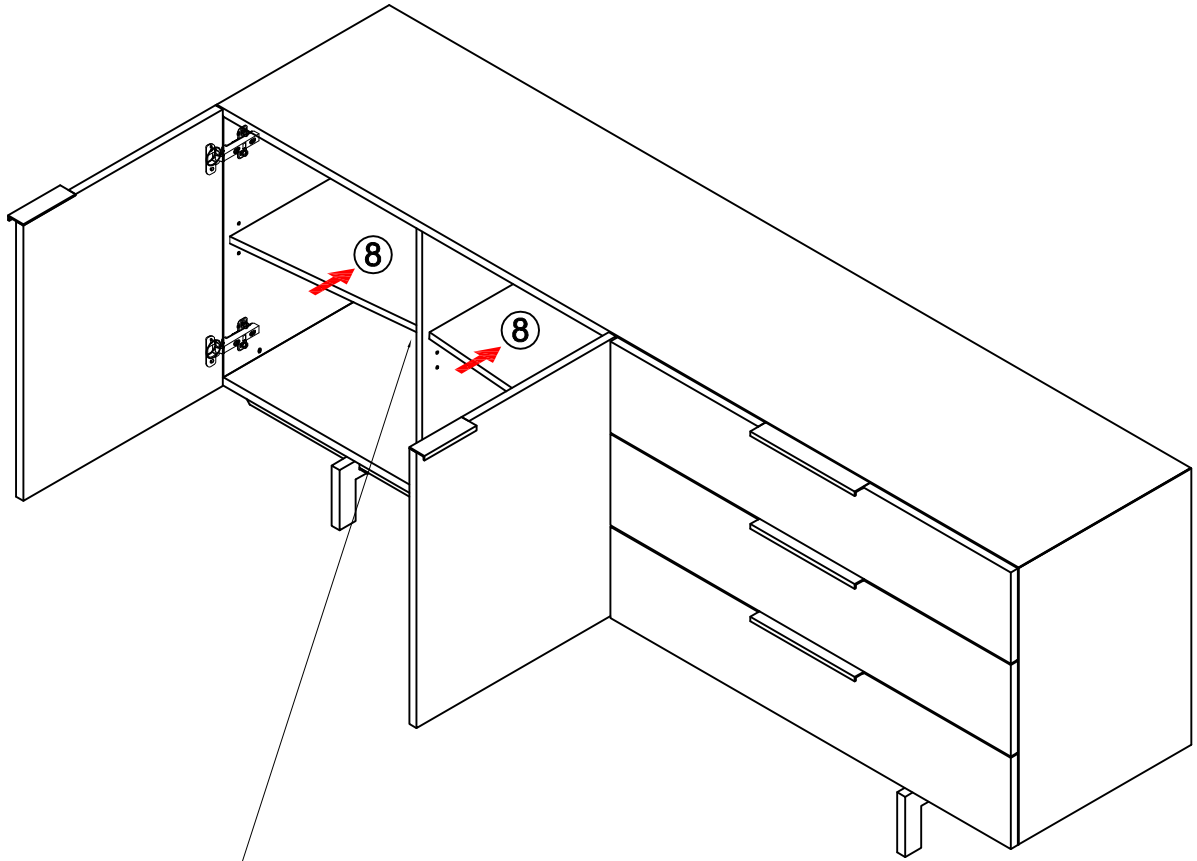

109	X8
	

21

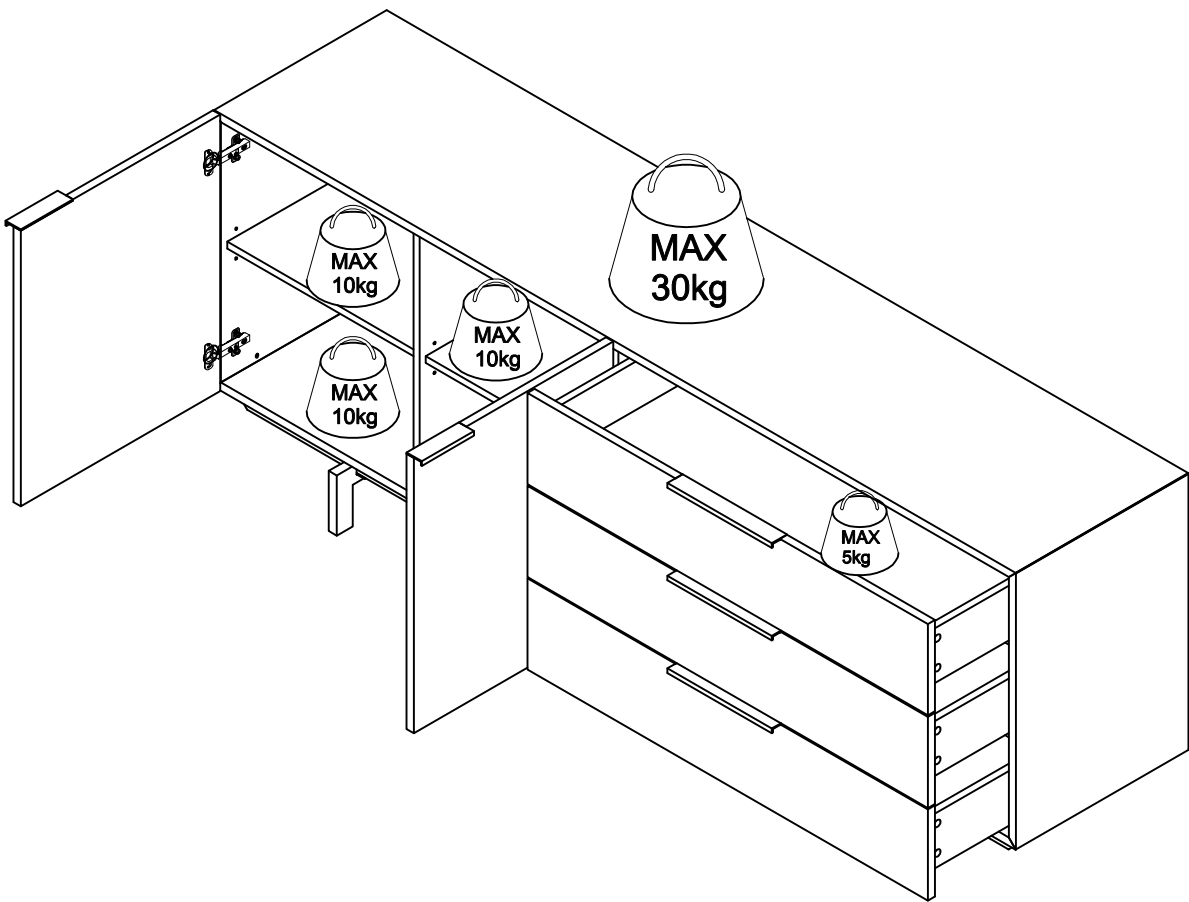



1. AVERTISSEMENT: Ne pas laisser l'enfant sans surveillance.

WARNING: Do not leave the child unattended.

ADVERTENCIA: No deje a los niños desatendidos.

WARNUNG: Lassen Sie das Kind nicht unbeaufsichtigt.

2. Toute partie additionnelle ou pièce de rechange doit seulement être obtenue du fabricant ou du distributeur.

Any additional or replacement parts shall only be obtained from the manufacturer or distributor.

Cualquier pieza adicional o de repuesto deberá obtenerse del fabricante o distribuidor.

Zubehör- oder Ersatzteile sollten Sie nur vom Hersteller oder Händler beziehen.

3. Entretien et maintenance:

Dépoussiérez régulièrement avec un chiffon sec.

Nettoyer avec du liquide de vaisselle et essuyer avec un chiffon humide.

Ne pas utiliser le produit si l'un des éléments semble endommagé, brisé ou manque.

Éviter de placer ce produit à proximité de feu ouvert et d'autres sources de forte chaleur telle qu'un radiateur.

Care and maintenance:

Remove dust regularly with a dry cloth.

Clean with dishwashing liquid and wipe with a damp cloth.

Do not use the product if any part appears damaged, broken or missing.

Be aware of the risk of open fire and other sources of strong heat, such as electric heaters, in the vicinity of the product.

Cuidado y mantenimiento:

Quite el polvo periódicamente con un paño seco.

Limpiar con líquido para lavar platos y limpie con un paño húmedo.

No utilice el producto si alguna de las piezas está dañada, rota o falta.

Conozca los riesgos de un fuego y de otras fuentes de calor fuerte, como los calefactores eléctricos, en las proximidades del producto.

Pflege und Wartung:

Entfernen Sie den Staub regelmäßig mit einem trockenen Tuch.

Reinigen Sie mit Spülmittel und wischen Sie mit einem feuchten Tuch.

Verwenden Sie das Produkt nicht, wenn Teile beschädigt, defekt sind oder fehlen.

Achten Sie auf die Gefahr von Feuer und anderen starken Wärmequellen in der Nähe des Produkts, wie elektrische Heizkörper.

Imported by - Importé par

CAFOM DISTRIBUTION

9 Rue Jacquart 93310 Le Pré-Saint-Gervais

Made in China/ Fabriqué en Chine

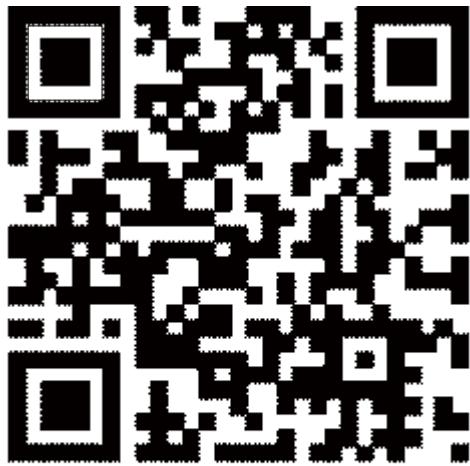

VS-Oct-2016